

Reference Guide for the DS7060 Control/Communicator

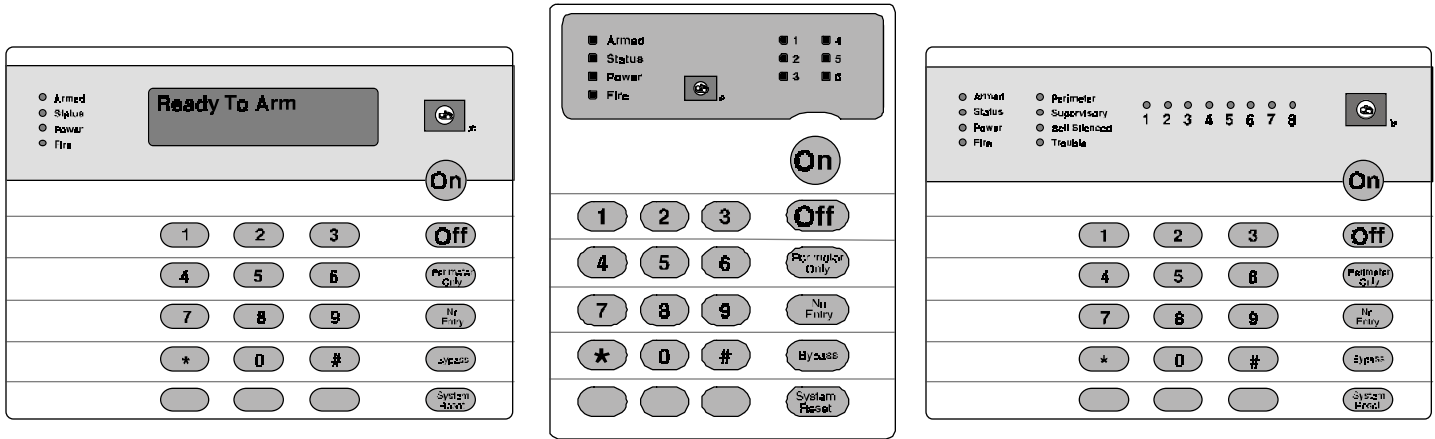

Keypad Quick Reference Guide

Turning On (arming) your System

Normal Arming	PIN + [On]
Perimeter Arming, no entry delay	PIN + [No Entry] [Perimeter Only]
Perimeter Arming, with entry delay	PIN + [Perimeter Only]
Maximum Security Arming	PIN + [No Entry] [On]
Force Arming	PIN + Arming Sequence + [Bypass]
Zone Bypass	PIN + [Bypass] followed by the Zone number
Quick Arm	[#] + [On]

Turning Off (disarming) your System

PIN + [Off]

Commands for other System Features

Chime Mode	PIN + [#] [7]
Zone Test	PIN + [#] [8] [1]
Read Alarm History	PIN + [#] [8] [9]
Battery Test	PIN + [System Reset]
Communicator Test	PIN + [#] [8] [2]
Fire Reset	PIN + [System Reset]
Fire Trouble	PIN + [Off] to silence, PIN + [System Reset] to clear
Remote Program Dial Out	PIN + [#] [8] [3]
Remote Program Answer	PIN + [#] [8] [6]
Local Battery/Sounder Test	PIN + [#] [8] [5]
Error Display	PIN + [#] [8] [7]
Error Display Reset	PIN + [System Reset]
Clear Zone Bypass	PIN + [Bypass] [*] to clear
Guest Code Enable	PIN + [#] [8] [4]

NOTE: Examples are shown in Commercial Mode but are valid for any mode.

For a detailed description of keypad commands, see the DS7060 User Guide P/N 29955.

Detection Systems PTY Ltd.
Unit 21, 45 Gilby Road
Mount Waverley, Victoria 3149, Australia
61 3 9558 8088 Fax: 61 3 9558 8089

Detection Systems PTY Ltd.
Unit 2, The Riverside Centre
148 James Ruse Drive
Parramatta, NSW 2150, Australia
61 2 891 4944 Fax: 61 2 891 5844

Detection Systems Int'l Inc.
19, Rue du 19 Mars-78130
Les Mureaux, France
Phone/Fax: 33 1 34 74 9576

Detection Systems Ltd.
Unit 13-18, 17/F New Commerce Centre
19 On Sum Street, Shatin, N.T.
Hong Kong
852 2635 2815 Fax: 852 2648 7986

Detection Systems, Inc., 130 Perinton Parkway, Fairport, New York, USA 14450-9199
(716) 223-4060 • (800) 289-0096 • Fax: (716) 223-9180

Table of Contents

1.0	SYSTEM OVERVIEW	3	7.30	Address 36 - Test Reports, System Test	22
2.0	SPECIFICATIONS	3	7.31	Address 37 - Account Codes	22
2.1	Enclosure Housing	3	7.32	Address 38 - Phone #1 Format	23
2.2	Temperature	3		Address 39 - Phone #2 Format	23
2.3	Power	3	7.33	Address 40-41 Phone #1 (Reporting)	23
2.4	Outputs	3		Address 42-43 Phone #2 (Reporting)	23
2.5	Zones	3		Address 44-45 Phone #3 (Remote Programming)	23
2.6	Keypads	3	7.34	Address 46 - Programmer & Master Codes	24
2.7	Communicator	3	7.35	Address 47 - Default EEPROM	24
2.8	Users	3	7.36	Address 48 - Automatic Test Report Interval	24
2.9	Lightning Protection	3	7.37	Address 49 - Hours to First Auto Test Report	24
2.10	Burglar/Fire Zone Inputs	3	7.38	Address 50 - AC Failure Report Delay	24
2.11	Line Seizure Notice	3	7.39	Address 51 - Keypad Language Programming	24
3.0	ENCLOSURE INSTALLATION	4	8.0	INSTALLATION GUIDE FOR U. L. LISTED SYSTEMS	25
3.1	Install the Enclosure	4	8.1	DS7060 U. L. Listings	25
3.2	Install the Control/Communicator	4	8.2	Installation Considerations	25
4.0	CONTROL TERMINAL WIRING	5	8.3	Programming the DS7060	26
5.0	SYSTEMWORKSHEETS	6		Household Fire Alarm (using Digital Alarm Communicator Transmitter with local bell)	26
6.0	HOW TO PROGRAM THE DS7060	8		Grade A Household Burglary Alarm (using Digital Alarm Communicator Transmitter with local bell)	26
7.0	PROGRAMMING THE DS7060	8		Local Burglary Alarm	27
7.1	Address 01 - Zone Programming	9		Police Station Connection	27
7.2	Address 02 - Zone Bypass	10		Central Station Burglary Alarm	28
7.3	Address 03 - Zone Action	10	8.4	Wiring and Programming Information for Installations Using the Ademco AB-12 Bell/Housing	30
7.4	Address 04 - Output Type	11	9.0	FCC COMPLIANCE NOTICE	30
7.5	Address 05 - Zone Response Time	11	10.0	FCC PHONE CONNECTION NOTICE TO USERS	30
7.6	Address 06 - Programmed Zone Response Time	12	11.0	CANADIAN DEPARTMENT OF COMMUNICATIONS	31
7.7	Address 07 - Zone Restoral Options	12	11.1	General Installation Requirements	31
7.8	Address 08 - Outputs	12	11.2	Terminal Requirements	31
7.9	Address 09 - User Control	13	11.3	RFI Requirements	31
7.10	Address 10 - General Control	14	12.0	FOR INSTALLATIONS IN NEW ZEALAND	31
7.11	Address 11 - Keypad Assignment	15	13.0	REPORT PROGRAMMING	32
7.12	Address 12 thru 18 - Alpha Label	15	13.1	Suggested Values	32
7.13	Address 19 - Special Keys	16		Personal Dialing Format	32
7.14	Address 20 - Report Control	16	13.2	Pager Format	32
7.15	Address 21 - Phone Number Control	17		Personal Dialing and Pager Format	33
7.16	Address 22 - Dial Attempts	17		4/2 Format (suggested values)	33
7.17	Address 23 - Time Delays	17	13.3	Values Sent	34
7.18	Address 24 - Keypad Report	18		High Speed 4/9 Format	34
7.19	Address 25 - Zone Alarm Report	18		Contact ID Format	36
7.20	Address 26 - Zone Alarm Restoral Report	19		SIA Format	37
7.21	Address 27 - Zone Trouble Report	19	14.0	Program Address Quick Reference Guide	38
7.22	Address 28 - Zone Trouble Restoral Report	19	Index	39	
7.23	Address 29 - Zone Bypass Report	20			
7.24	Address 30 - Zone Bypass Restoral Report	20			
7.25	Address 31 - Open/Close Duress Report	20			
7.26	Address 32 - Battery, AC Report	21			
7.27	Address 33 - Programming Report	21			
7.28	Address 34 - System Report	21			
7.29	Address 35 - Exit Error, Recent Closing, Comm. Failure Report	22			

1.0 SYSTEM OVERVIEW

The DS7060 Control/Communicator is a fully integrated hard-wire security and residential fire alarm system. It can support up to 6 input zones and 15 individual users. Up to 4 keypads may be used to provide user interface with the system, as well as programming access for the installer.

2.0 SPECIFICATIONS

2.1 Enclosure Housing

The enclosure is manufactured from 22 Ga. (0.65 mm), cold-rolled steel, and measures 9.25" Wide, by 10.25" High, by 3" Deep (23.5 cm Wide, by 26 cm High, by 7.6 cm Deep). The door has a knockout for a standard DS lock (optional). The enclosure has a slot in the back and also has an optional tamper switch mounting bracket with a plunger switch.

2.2 Temperature

- Operating temperature: +32°F to +120°F (0°C to +49°C)
- Storage temperature: -20°F to +150°F (-28°C to +66°C)

2.3 Power

- Input Power: 16.5 VAC, 20 VA, 50 or 60 Hz
- Auxiliary Regulated Power: 12-12.5 VDC, 0.8 A
- Auxiliary Power Voltage Range: 10 to 13.8 VDC
- Optional Standby battery (P334): 12 V, 7.0 AH
- Control Panel Current Draw: 65 mA
- DS7443 Keypad Current Draw: 45 mA, Standby 45 mA, Alarm
- DS7445 Keypad Current Draw: 75 mA, Standby 75 mA, Alarm
- DS7447 Keypad Current Draw: 100 mA, Standby 100mA, Alarm

2.4 Outputs

The total combined power output of the Programmable Outputs, Keypads and Accessories cannot exceed 800 mA.

- Programmable Output 1* Solid state, switch to ground (500 mA max.).
- Programmable Output 2* Solid state, switch to ground (500 mA max.).
- Programmable Output 3** Contacts switch to 12 V @ 750 mA.

* = The combined current draw of Programmable Output 1 and Programmable Output 2 cannot exceed 750 mA.

** = The combined current draw of Programmable Output 3 and the keypads cannot exceed 750 mA.

Refer to Section 7.8 for detailed Output operation.

2.5 Zones

- 6 zones
- Zone Response Time: All six zones can be programmed to respond at either 300 ±100 ms or a programmable time (common to all zones) that can be configured to be between 10 ms and 2.5 seconds. Zones are ignored for 15 seconds after power up, and for two seconds after a system reset.

Refer to Sections 7.2 - 7.7 for detailed zone operation.

2.6 Keypads

- Total number of keypads: 4 Keypads
- Maximum wire length total in system: 1000 ft. (305 m)
- Wire type: 22 AWG (0.8 mm)

NOTE: Keypads may be up to 1000 ft. (305 m) from the panel when #22 (0.8 mm) wire is used. Keypads may be "home-run" or "daisy-chained" with a maximum of two keypads per wire run.

2.7 Communicator

Will report to two phone numbers with full single, double, and backup reporting. Communicated in 3/1, 3/1E, 3/1 with Parity, 3/1E with Parity, 4/1, 4/2, High Speed 4/9, Pager, SIA (110 and 300 baud), Contact ID, and Personal Dialing formats.

Refer to Sections 7.14 - 7.33 for communicator operation.

The ringer equivalence is 0.1 B.

2.8 Users

The system allows up to 15 individual users. Each user will have his own PIN number (the 4 digit code entered at the keypads).

See Address 46 (Section 7.34) for programming the Master PIN Number. Refer to Users Guide (P/N 29955) for PIN programming.

2.9 Lightning Protection

MOVs and/or spark gaps provide protection from lightning surges and static discharges.

2.10 Burglar/Fire Zone Inputs

- Number of Circuits: 6 Circuits on board
- End-of-Line Resistor: 2.21k ohms

NOTE: 4 wire type smoke detectors only.

2.11 Line Seizure Notice

This control panel incorporates a line seizure feature which will disable internal telephone lines when the control panel is sending alarm or supervision reports to the central station.

3.0 ENCLOSURE INSTALLATION

The DS7060 control/communicator and the enclosure are shipped together. The control, however, still needs to be installed into the enclosure. Hardware for mounting the enclosure to a wall, and the control to the enclosure is located in its own hardware pack.

3.1 Install the Enclosure

NOTE: This panel is intended for mounting in a restricted access area and should be wall mounted.

CAUTION: The control panel should only be installed by authorized service personnel.

- Use the enclosure as a template and mark the mounting holes on the mounting surface.
- Pre-start the mounting screws for these holes. Mount the enclosure.
- Knock out the desired wire entrances on the enclosure.

3.2 Install the Control/Communicator

CAUTION: The control is static sensitive. Make sure you touch earth ground before handling the control. This will discharge any static electricity in your body.

EXAMPLE: Run the ground wire to the enclosure before handling the control. Then, holding the ground wire (or using a ground strap), install the control.

- Insert the two support posts into the control retainer holes as shown below in the Support Post Assembly diagram.
- Slide the top of the control PCB into the two retainer tabs.
- Once in the retainer tabs, the control will rest on the two support posts.
- Secure the bottom of the enclosure by screwing the bottom two holes through the support posts and through to the control retainer holes.

CAUTION: Once the control is installed, be sure to connect its ground wire to the top hinge of the enclosure.

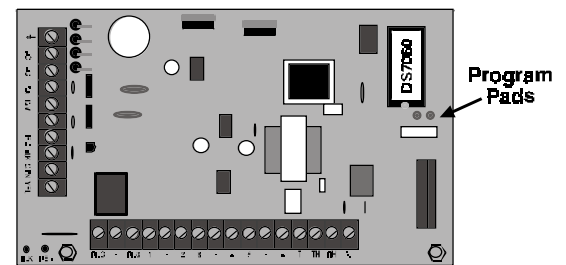
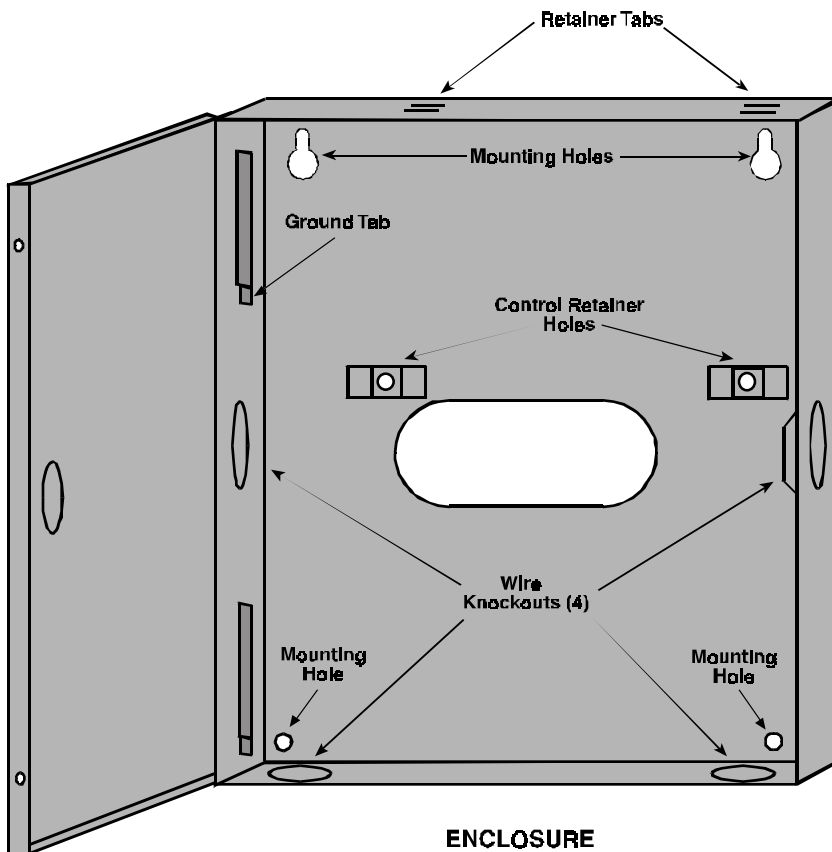

CONTROL/COMMUNICATOR

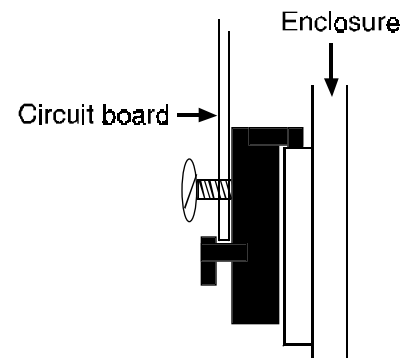

SUPPORT POST ASSEMBLY

4.0 CONTROL TERMINAL WIRING

WARNING: Before servicing this equipment, remove all power including the transformer and battery. Also remove the phone line connection. A complete functional test is required after any programming.

CAUTION: Danger of explosion if battery is incorrectly replaced. Replace only with the same or equivalent type recommended by the manufacturer. Dispose of used batteries according to the manufacturers instructions.

CAUTION: Incorrect connections may result in damage to the unit.

CAUTION: An appropriate two-pole disconnect device must be installed by qualified service personnel, as part of the building installation.

NOTE: Shared cable is not allowed for keypad, telephone, or siren wiring.

EARTH GROUND: Must be connected to a good earth ground such as a cold water pipe and also connected to the cabinet cover, using the supplied wire jumper.		1
A/C INPUT: Use U. L. listed 16.5 VAC 20 VA, Class 2 transformer Model TR-16. Requires 50/60 Hz unswitched dedicated outlet - Do Not Share	AC	2
	AC	3
PROGRAMMABLE OUTPUT 1: Shorts to common (-) when activated, 500 mA max. .	PO1	4
	12V	5
PROGRAMMABLE OUTPUT 2: Shorts to common (-) when activated, 500 mA max.	PO2	6
KEYPADS: Up to 4 keypads may be used. Maximum wire length is 1000 ft. (305 m) of 22 AWG (0.8 mm). Can be "home-run" or up to two keypads may be "daisy-chained" per wire run.	RED	7
	BLK	8
	GRN	9
	YEL	10

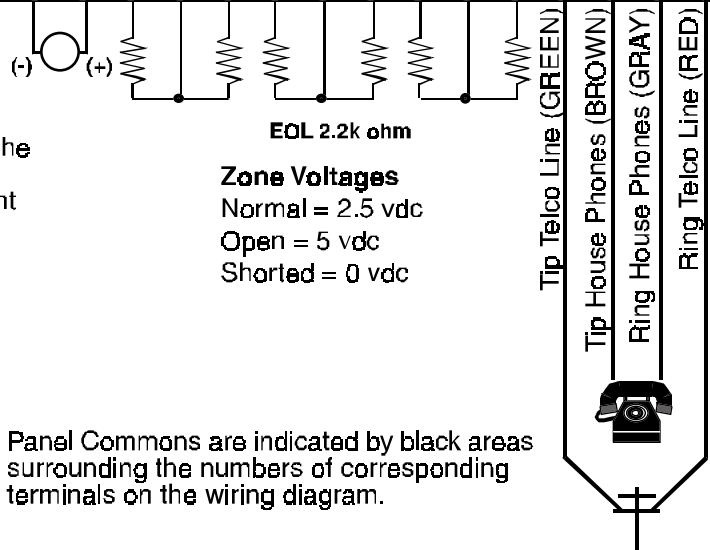
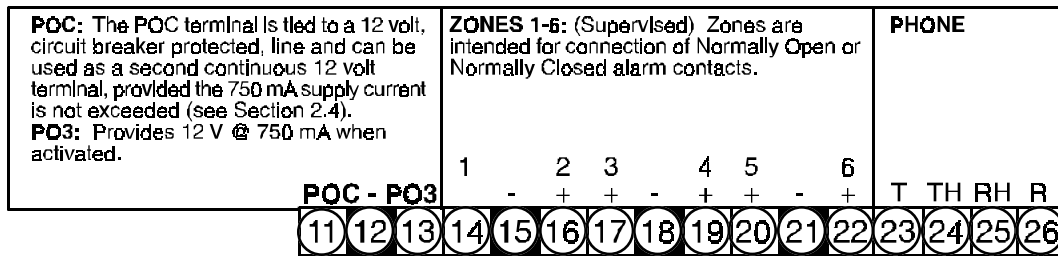
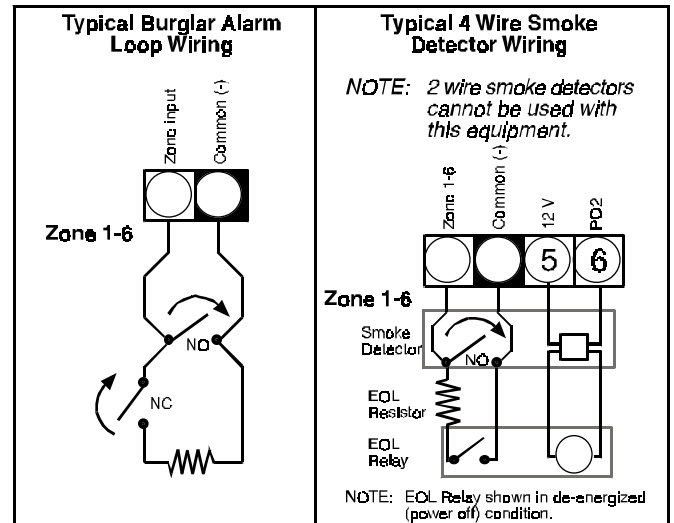

NOTE: PO3 output current is 750 mA minus the total keypad current. Example: If four 7447 keypads at 100 mA each are used, the current available at PO3 is 350 mA.

$$750 \text{ mA} - 400 \text{ mA} = 350 \text{ mA}$$

available keypads at PO3



 Panel Commons are indicated by black areas surrounding the numbers of corresponding terminals on the wiring diagram.

5.0 SYSTEM WORKSHEETS

Account Number _____ Information

Name _____ Contact Person _____
Address _____ Voice Phone Number _____
_____ Panel Phone Number _____
City, State, Zip _____ Panel Answers Phone Armed Disarmed

Equipment Location and Notes

AC Voltage _____ VAC Battery Voltage _____ VDC AUX Current _____ mA
Control Panel _____
Transformer _____
Telephone Jack _____
Telephone On Same Line as Panel _____
Earth Ground Connection _____
Alarm Sounder(s) _____

Misc. Notes

Keypad Location

Keypad #1 _____
Keypad #2 _____
Keypad #3 _____
Keypad #4 _____

	PIN NUMBER	NAME
<i>Example</i>	<u>1038</u>	<u>Henry M. Jones</u>
User 001	_____	_____
User 002	_____	_____
User 003	_____	_____
User 004	_____	_____
User 005	_____	_____
User 006	_____	_____
User 007	_____	_____
User 008	_____	_____
User 009	_____	_____
User 010	_____	_____
User 011	_____	_____
User 012	_____	_____
User 013	_____	_____
User 014	_____	_____
User 015	_____	_____

	DEVICE	LOCATION	TYPE
<i>Example</i>	<u>PIR</u>	<u>KITCHEN</u>	<u>Invisible alarm, alarm on short, alarm on open, 24-hour</u>
Zone 1	_____	_____	_____
Zone 2	_____	_____	_____
Zone 3	_____	_____	_____
Zone 4	_____	_____	_____
Zone 5	_____	_____	_____
Zone 6	_____	_____	_____

6.0 HOW TO PROGRAM THE DS7060

To enter the programming mode, the panel must be disarmed. When in the programming mode the control is disabled and no alarms will be processed, including 24-hour zones and fire zones.

To enter the Programmer's Mode, enter the Programmer's Code followed by [#] [0]. The default Programmer's Code is 9876. Enter the Program Address, i.e. [0] [2]. Press the [#] to change the values. After all values have been changed, press the [#] to accept the changes and return to the Program Address. Repeat the above until all addresses are programmed.

NOTE: Some data digit values are higher than 9. These values are programmed by pressing the reset [*] key followed by another number. These values will display as HEX characters when entered. The HEX character values are:

*0 = A, *1 = B, *2 = C, *3 = D, *4 = E, *5 = F.

To exit the Programmer's Mode, press the [*] key for 2 seconds. Also, if no keypad entries are made for 4 minutes, the control will automatically exit from the Programmer's Mode.

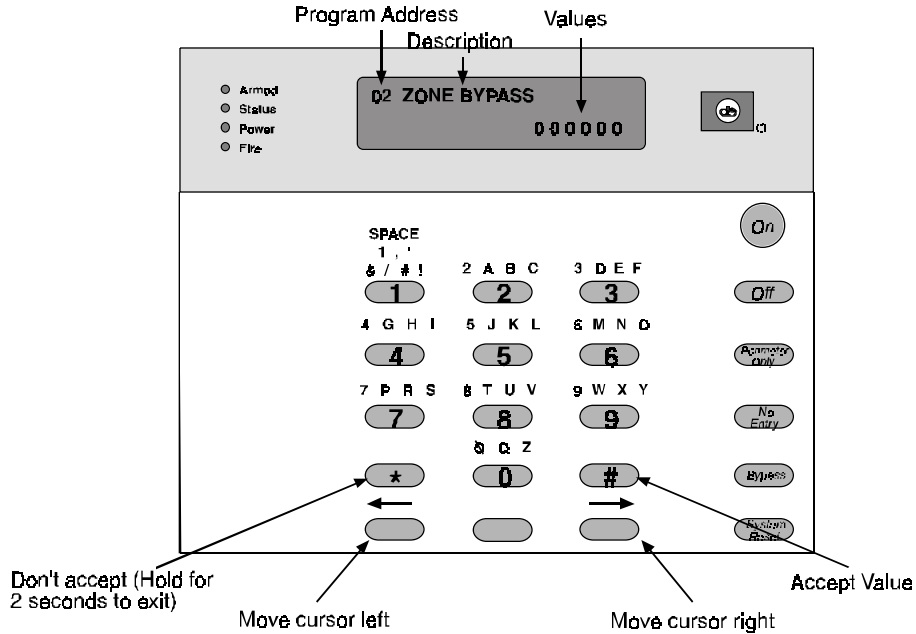

7.0 PROGRAMMING THE DS7060

Most control panel functions are controlled using a single program address. Some functions are grouped into one address. For example: The keypad emergency keys are programmed in Address 19. The first data digit of this address is for the Fire Key, the second is for the Help Key, and the third is for the Panic Key. Other addresses are configured this way also, with the address representing a group of functions and each data digit controlling a specific function.

Example: To program the Fire Key as Pulsing Audible, the Help Key as Steady Audible and the Panic Key as Invisible.

Use the following chart for each Address to record your selections before programming.

- 0 = Disabled
- 1 = Invisible
- 2 = Steady Audible
- 3 = Pulsing Audible

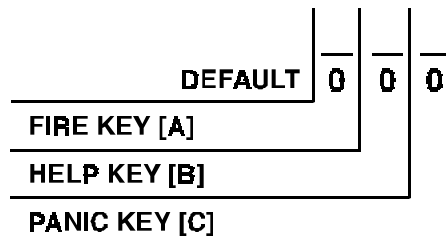

Enter the Programmer's Mode: [9] [8] [7] [6] [#] [0] will display the program mode
 Enter the Program Address: [1] [9]
 Enter: [#] to change the values
 Enter: [3] in the first data field to change the Fire Key to Pulsing Audible
 Enter: [2] in the second data field to change the Help Key to Steady Audible
 Enter: [1] in the third data field to change the Panic Key to Invisible
 Enter the Pound button: [#]
 Program the next Address, a different Address, or exit the Programmer's Mode.

7.1 Address 01 - Zone Programming

A zone is an input to the DS7060 Control/Communicator. There are 6 hard-wired zones on the main circuit board.

- 0 = Disabled
- 1 = Perimeter Instant
- 2 = 24 Hour
- 3 = Perimeter Delayed
- 4 = Interior Follower
- 5 = Interior Home/Away
- 6 = Interior Instant
- 7 = Perimeter Homeguard
- 8 = Perimeter Follower Homeguard
- 9 = Silence Audible
- A = Keyswitch Toggle
- B = Keyswitch On/Off
- C = 24 Hour Fire w/Verify
- D = Fire

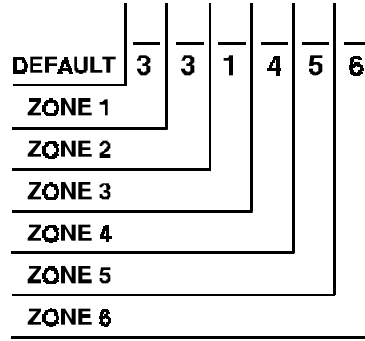

- **Disabled:** These zones are not monitored, and will not generate alarm or trouble conditions.
- **Perimeter Instant:** These zones arm and disarm with the panel, and never have entry or exit delays. Violation of this type of zone will cause an intrusion alarm.
- **24-Hour Auxiliary:** This zone type will cause an auxiliary alarm. It is always active. An alarm on a 24-hour zone (fire or aux.) will be silenced by entering a disarm code whether the control is armed or not. If the 24-hour zone restores and alarms again the alarm will sound again. 24-hour zones may generate trouble conditions during armed or disarmed periods. All 24-hour zones that have alarmed and are not restored will show as "Not Ready." They will prevent arming unless the panel is force armed. 24-hour zones that have been bypassed manually will remain so until manually unbypassed, even if the control is armed and disarmed. Bypasses of these zones will be displayed on the keypad.
- **Perimeter Delayed:** These zones have entry or exit delays unless the panel is armed in the "No Entry" mode. In the "No Entry" mode, the exit delay is in effect immediately after entering the "No Entry" mode, but is disabled upon expiration of the exit delay.

A delayed zone is ignored during the programmed times immediately following arming during the exit delay. If the zone is faulted while the control is armed and not in exit delay then an entry delay cycle will be started, and a continuous entry tone will be sounded at the keypads. If the control is not disarmed by the end of the entry delay, an alarm will result. There are no keypad tones during the exit delay unless the feature "Keypad Audible During Exit Delay" is selected. Refer to Section 7.9, Address 09. If an entry delay is running and another entry delay zone is faulted, the entry delay timer is unaffected and will continue timing from the first entry. The entry delay time and exit delay time can be set independently.

If a delayed zone remains faulted at the end of an exit delay, the panel will optionally signal an exit error condition. The entry delay will begin as above, and the alarm output will activate with the pattern selected for that zone. If the control is not disarmed by the end of the entry delay, an alarm will result, and an exit error report will be sent to the central station (following the alarm report if programmed). The alarm output will deactivate. If the control is disarmed during the delay period started by the exit error condition, no reports will be sent to the central station and any outputs on during the exit error will deactivate. The exit error report does not follow the dialer delay option.

- **Interior Follower:** This zone is not active when the panel is disarmed, or is armed in the perimeter only mode. When the zone is active, if a delayed zone is violated first, this zone is also delayed. If an instant zone or this zone type is violated first, this zone is not delayed. This zone is not active during the exit delay.
- **Interior Home/Away:** This zone becomes interior instant if the system is armed and an entry/exit delay zone is violated during the exit delay time. If the system is armed and an entry/exit zone is not violated, these zones will be bypassed. These zones are bypassed if armed perimeter only.
- **Interior Instant:** These zones arm and disarm with the panel. They are not active if the panel is armed in the "perimeter only" mode. They never have entry or exit delays. Violation of this type of zone will cause an intrusion alarm.
- **Perimeter Homeguard:** This zone type is active when the panel is armed. When the panel is armed perimeter only, this is a delayed zone. When armed full, this is an instant zone.
- **Perimeter Follower Homeguard:** These zones are always delayed when the panel is armed in the perimeter only mode. When the panel is fully armed, these zones are delayed if a delayed zone is violated first, or instant if this zone or an instant zone is violated first.
- **Silence Audible:** A zone configured as Silence Audible will, when activated, cause the panel to shut off output PO3 and keypad sounders. When this zone restores, the sounders will reactivate (if the timeout has not expired). It is used to facilitate voice communication for listen-in modules.

- **Keyswitch Toggle:** Each time this zone is closed, it will toggle the armed state of the panel. It has a 300 ms response time. No alarms or trouble conditions are generated by a zone of this type. Optionally, to support this feature, the panel will generate a single siren beep for arm actions and a double beep for disarm actions. **Note:** If "Auto Bypass" is enabled (Address 10), Keyswitch Toggle will force arm a "Not Ready" zone.
- **Keyswitch On/Off:** When this zone is closed, it will arm the panel. When it is shunted by an EOL (supervised), the panel will be disarmed. No alarms or trouble conditions will be generated by a zone of this type. Opening the zone will not affect the arming state of the control. When this option is selected, keypads can not be used to arm or disarm the system unless the keyswitch zone is manually bypassed, prior to arming the system, from the keypad. If the keyswitch zone is bypassed, any keypad can perform all arming and disarming functions. **Note:** If "Auto Bypass" is enabled (Address 10), Keyswitch On/Off will force arm a "Not Ready" zone.
- **24-Hour Fire with Verification:** If a fire zone alarms and it is programmed for verification, the control will interrupt the programmable output(s) set as a switched power return for 10 seconds. During the 10 second power interruption, and for 15 seconds after power restoration, it will ignore all zone status on all fire zones (to ignore inrush currents). After fifteen seconds, it will monitor all fire zones for two minutes. If any fire zone returns to alarm within the two minute window it will create a fire alarm condition. If a fire zone does not go into alarm within the two minute window it will disregard the initial trip. If another alarm occurs on a fire zone with verification after the two minutes, it will start the process over. After any fire zone is in alarm, all subsequent fire zones are treated as instant (no verification) until the next fire reset. This same procedure will be performed when a [SYSTEM RESET] is entered, except that the two minute instant alarm monitoring period is not observed.

Since alarm and trouble reporting to the central station for fire zones is the same as for burg zones (i.e. it is based on the state of the zone) it is possible for Fire, and Fire Trouble restoral signals to be transmitted even though the panel may still be displaying these zone conditions. This is because the displays are latched until cleared by an operator action.

NOTE: The use of the controls fire alarm verification feature may not be permitted in some areas. Check your local fire/building codes.

- **Fire:** This zone is active and will alarm all 24 hours of the day regardless of the arming state of the control. An alarm on a fire zone will be silenced by entering a disarm code whether the control is armed or not. If the fire zone restores and alarms again the alarm will sound again. An open during the armed or disarmed period will send a trouble report and not an alarm. Fire zones are never silent, invisible, or swinger shunted. All fire zones that have alarmed will continue to show on all keypads until a fire reset is performed, even if they have physically restored. Fire zones may not be bypassed using the BYPASS command.

NOTE: If force arming is enabled (see programming address 10), force arming is possible when the fire zone is violated (shorted).

7.2 Address 02 - Zone Bypass

This determines whether the user can bypass the zone. Zones programmed for bypassing can be bypassed even when in alarm. Fire zones will not be bypassable, even if programmed as bypass allowed.

0 = Bypass Not Allowed
1 = Bypass Allowed

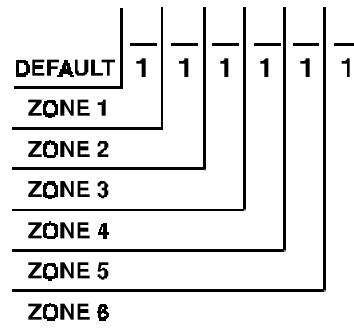

7.3 Address 03 - Zone Action

0 = Alarm on Short, Alarm on Open
1 = Alarm on Short, Trouble on Open
2 = Alarm on Open, Trouble on Short

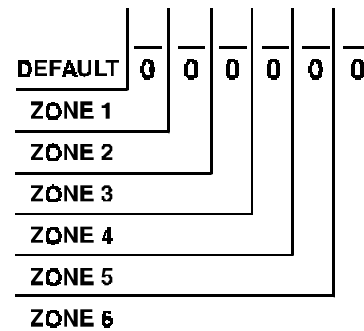

NOTE: Fire zones should always be programmed as alarm on short, trouble on open (selection 1).

- **Alarm on Short:** This zone will alarm when the loop is shorted and the system is armed. It will generate a "Not Ready" (or "Fire Trouble" on fire zones) while unarmed and prevent arming unless the problem is cleared, Forced Armed, or Bypassed.
- **Alarm on Open:** Works like Alarm on Short, but alarms when loop is opened.
- **Trouble on Short:** This zone will alarm when the loop is shorted and the system is armed. It will generate a "Trouble" while unarmed and prevent arming unless the problem is cleared, Forced Armed, or Bypassed.
- **Trouble on Open:** Works like Trouble on Short, but alarms when loop is opened.

7.4 Address 04 - Output Type

- 0 = Invisible (not valid for fire zone)
- 1 = Silent (not valid for fire zone)
- 2 = Steady
- 3 = Pulsing (PO3 only)

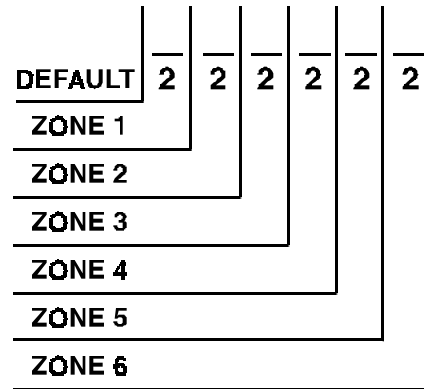

- **Invisible:** This is a zone programmed **not** to have an alarm output or an alarm display at any keypad when activated. An alarm signal will be sent, but the keypad display will not indicate an alarm while this zone is violated. Invisible alarm zones are recommended for holdup alarms.
- **Silent:** This is a zone programmed to activate the visual display at the keypad, but **not** audible signals. If this zone is also an entry zone, an entry tone will sound when this zone is activated.
- **Steady:** When this zone alarms all programmed outputs (prog1/prog2/prog3) will come on steady, unless they are already pulsing, in which case they will remain pulsing.
- **Pulsing:** The pattern for the pulsing audible output will be 0.5 sec on, 0.5 sec off repeated three times, with an additional 1 second delay between repeats. When zones are tripped which could cause both pulsing and steady outputs, the pulsing output will prevail. The alarm outputs will continue to be activated until the bell cutoff timer times out or is reset and then they will silence. Only programmable output 3 and the keypad sounders will pulse, regardless of the programming.

7.5 Address 05 - Zone Response Time

All six zones can be programmed to respond at either 300 ms (± 100 ms) or a programmable time (common to all zones, the time is programmed into Address 06) that can be configured to be between 160 ms and 2.5 seconds.

- 0 = Use the Default Response Time (300 ms)
- 1 = Use the Response Time Programmed in Address 06

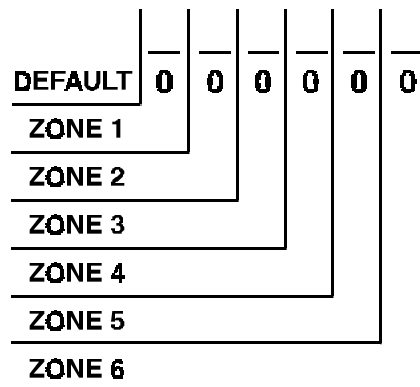

7.6 Address 06 - Programmed Zone Response Time

Sets the time value used in Address 05.

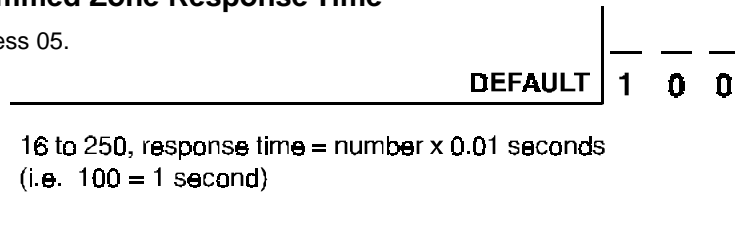

7.7 Address 07 - Zone Restoral Options

- 0 = Restore when Sounders Silence
- 1 = Restore with Zone
- 2 = Restore when Disarmed (or Reset)

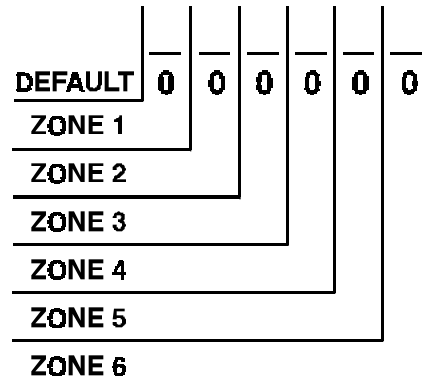

- **Restore when Sounders Silence:** If programmed, a zone sends a restoral report and is ready to activate again only after the burglary bell cutoff time expires or the bells are silenced. The zone can alarm multiple times per armed period.
- **Restore with Zone:** If programmed, a zone sends a restoral report and is ready to activate again as soon as it physically restores. The zone can alarm multiple times per armed period.
- **Restore when Disarmed (or Reset):** If the zone returns to normal before the bell timer elapses, the alarm display will continue and no restoral will be reported. When the bell timer then elapses, whether or not the zone has restored, the bell will shut down (if selected) but the alarm display will continue and no restoral will be reported. When the system is disarmed (or reset) the bell will silence, the displays will clear and restoral will be reported along with the open/reset event (if programmed). If the zone is a 24 hour zone and has not restored to normal, will not report zone restoral until the zone restores. Unrestored 24 hour zones will show as "not ready" and will prevent the system from arming. In this case, the system will reinitiate the sounders and displays for those zones, but will not send any fire alarm transmission to the central station for those zones, unless a previous restoral has been sent. Fire zones always restore when the system is reset, regardless of this selection.

7.8 Address 08 - Outputs

- 0 = Intrusion
- 1 = On During Entry Pre-Alert
- 2 = System Reset
- 3 = Armed
- 4 = Ground Start
- 5 = Ready to Arm
- 6 = Follow Burg Alarm
- 7 = Follow Fire Alarm
- 8 = Follow Burg and Fire Alarm
- 9 = Follow Keypad Saucer
- A = Duress
- B = Trouble

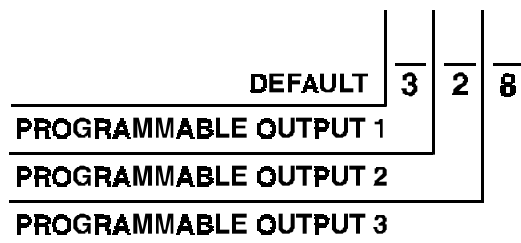

- **Intrusion:** This is an output programmed to latch with any Burg zone alarm, including invisible and silent zones. It will remain latched until the system is disarmed regardless of the restore setting for the zone.
- **On During Entry Pre-Alert:** This is an output programmed to activate when a perimeter delayed type zone is violated while the system is armed. It will remain activated until the system is disarmed, or until the entry delay time has expired.
- **System Reset:** This is an output programmed to activate only for 10 seconds after a PIN + [System Reset] is entered at a keypad or if a fire zone with verification activates. Output 1 turns on for 10 seconds, outputs 2 and 3 turn off for 10 seconds. Outputs 2 and 3 are intended to be used to power 4-wire smoke detectors or any other device that requires a power interruption to reset an alarm condition.

- **Armed:** This is an output programmed to activate when the system is armed. It will remain activated until the system is disarmed.
- **Ground Start:** This is an output programmed to activate for 3 seconds when the phone line is seized. It is intended for use with ground start phone systems that require a momentary short to ground to obtain a dial tone. Connect a separate 12 VDC, DPDT relay. Connect both relay commons to ground, and connect the N/O of each contact to terminal positions 23 and 26 (one to terminal 23, one to 26) of the DS7060. Connect one side of the relay coil to the selected Programmable Output and the other side of the coil to 12 volts (Terminal 5) (if PO1 or PO2 is used), or to any Panel Common terminal if PO3 is used. Not intended for U. L. Listed systems. Not for use with phone line monitors.
- **Ready to Arm (System Status):** This is an output programmed to follow the "Status" light of the keypad. It will activate when the system is ready to arm with no zones violated.
- **Follow Burg Alarm:** This is an output programmed to activate when a zone is in an alarm condition. It will remain activated until the system is disarmed or the bell cutoff time expires. This output is intended to activate bells and sirens. This will not activate from Silent or Invisible zones.
- **Follow Fire Alarm:** This is an output programmed to activate when a zone is in an fire alarm condition. It will remain activated until the system is disarmed or the bell cutoff time expires. This output is intended to activate bells and sirens. This will not activate from Silent or Invisible zones.
- **Follow Burg and Fire Alarm:** This programs an output to activate when any zone goes into alarm condition.
- **Follow Keypad Sounder:** This is an output programmed to follow the keypad sounder. It activates during the entry pre-alert. It does not follow momentary keypad beeps such as keystrokes.
- **Duress:** This output activates when the duress code is used to disarm the system. **Note:** If the Duress code is used to activate a Programmable Output, entering any valid PIN + [OFF] will deactivate the Programmable Output.
- **Trouble:** This output activates when a trouble condition is present.

7.9 Address 09 - User Control

	DEFAULT	0	0	0	0	0
Duress Code 0 = Code 14 is a User Code 1 = Code 14 is the Duress Code						
Guest Code 0 = Code 15 is a User Code 1 = Code 15 is the Guest Code						
Arming Warning 0 = No Alarm 1 = 2 Second Alarm						
Keypad Audible During Exit Delay 0 = No Audible 1 = Audible During Delay						
Keyswitch Arming Warning 0 = No Audible 1 = Audible Beep w/Arming 2 Beeps with Disarming						

- **Duress Code:** If this option is selected and Code 14 is used to disarm the system, a duress report will be sent as the system is otherwise disarmed normally. User Code 14 will not arm the system, or report duress, if the system is not armed.
- **Guest Code:** If this option is selected, Code 15 is a guest code. It can be enabled by pressing [PIN] [#] [8] [4]. It will remain active until the panel is disarmed with any other valid code.
- **Arming Warning:** If this option is selected, the alarm output will turn on for 2 seconds when the panel is armed.
- **Keypad Audible During Exit Delay:** Selection of this option will cause the keypad sounders to beep during the exit delay time. A one second beep will sound at 5 second intervals, changing to a 3-beep tone at 10 and 5 seconds prior to the end of the delay.
- **Keyswitch Arming Warning:** Selecting this option will activate any output programmed as Intrusion, Follow Burg Alarm, or Follow Burg Alarm and Fire Alarm. The output will beep once (200 ms ON) when a keyswitch toggle zone arms the system. A double beep will occur (200 ms ON-OFF-ON) when a keyswitch toggle zone disarms the system.

7.10 Address 10 - General Control

	DEFAULT	0	0	0	0	0	0	0	0
Siren on Comm. Fail for Silent Zone 0 = No 1 = Yes									
Closing Ringback 0 = Closing Ringback Disabled 1 = Closing Ringback Enabled									
Swinger Shunt 0 = Swinger Shunt Disabled 1 = Swinger Shunt Enabled									
50 Hz/60 Hz 0 = 60 Hz 1 = 50 Hz									
Keypad Mode 0 = Commercial Mode 1 = Residential Mode									
Quick Arm 0 = Quick Arm Disabled 1 = Quick Arm Enabled									
Easy Exit 0 = Easy Exit Disabled 1 = Easy Exit Enabled									
Auto Bypass 0 = Auto Bypass Disabled 1 = Auto Bypass Enabled									
Force Arming Limit 0 = Force Arming Disabled 1- 6 = Number of zones allowed to Force Arm									

- **Siren on Comm. Fail for Silent Zone:** If programmed, a silent zone will sound the alarm outputs if the zone is in an alarm condition and the system fails to communicate with the central station.
- **Closing Ringback:** If programmed, the keypad sounders and Output 3 will activate for 2 seconds after the system is armed and the closing report is successfully sent. This requires Closing Ringback and Closing Report to be programmed.
- **Swinger Shunt:** If enabled, a zone can only alarm or trouble up to three times per armed period. After the third alarm or trouble, the zone will be bypassed and a bypass report for this zone will be sent. Fire zones are never swinger shunted.
- **50 Hz/60 Hz:** Set to local power type. The panel clock is synchronized to the power line frequency. 60 Hz required for U.L. Listed Requirements.
- **Keypad Mode:** Commercial Mode requires a PIN number for all functions. Residential Mode only requires a PIN number for disarming and silencing alarms.
- **Quick Arm:** If enabled, a PIN is not needed to arm. Note: Used only in conjunction with commercial mode.
- **Easy Exit:** If the system is armed and there have been no zones violated, then you can reenter a Quick Arm Command without first disarming the system. This allows you to change the arming level or to restart the exit delay so you can exit through an entry/exit zone.
- **Force Arming Limit:** If enabled, the system can be armed when zones are violated or if an AC power failure has occurred, by pressing the [Bypass Key] after an arming command. If bypassing is not allowed, a three beep error tone will sound and the panel will return to standby mode. **Note:** If "Auto Bypass" (Address 10) is enabled, arming the panel will automatically bypass the corresponding number of zones programmed into Force Arming Limit. If "Auto Bypass" is disabled, any zones that were programmed to be bypasses in Address 02, may be Auto Bypassed.
- **Auto Bypass:** If enabled, the system will automatically bypass faulted zones when an arming command is used. If bypassing is not allowed on the "Not Ready" zone, a three beep error tone will sound, and the panel will return to standby mode. **Note:** When enabling Auto Bypass, it may be desirable to program "Force Arming Limit" (Address 10). If "Force Arming Limit" is set to 0, Auto Bypass will allow bypassing of any zone that was programmed to be bypassed by Address 02. If "Force Arming limit" is programmed between 1 and 6, this is the maximum number of zones that can be Auto Bypassed.

7.11 Address 11 - Keypad Assignment

The keypad type (LED or Alpha) or no keypad must be programmed.

- 0 = No Keypad or Keypad Disabled
- 1 = LED Keypad
- 2 = Alpha Keypad

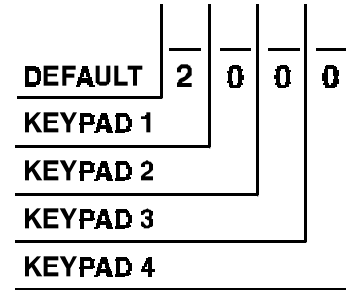

7.12 Address 12 thru 18 - Alpha Label

Address 12 - Private Label:

The private label will display when the system is Ready to Arm and when it is Armed.

Address 13 - Zone 1 Alpha Label:

Address 14 - Zone 2 Alpha Label:

Address 15 - Zone 3 Alpha Label:

Address 16 - Zone 4 Alpha Label:

Address 17 - Zone 5 Alpha Label:

Address 18 - Zone 6 Alpha Label:

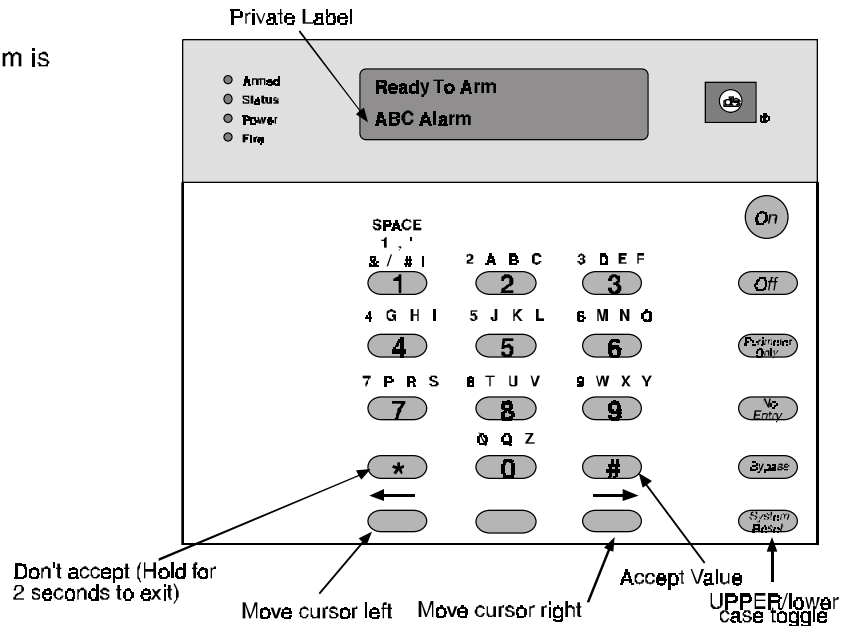

Example: To program "ABC Alarm" as the Private Label

- Enter the Programmer's Mode: [9] [8] [7] [6] [#] [0]
- Enter the Program Address: [1] [2] followed by [#]
- Enter: [2] for the letter "A" then press the right arrow key to continue with the next letter
- Enter: [2] twice for the letter "B" then press the right arrow key for the next letter.
- Enter: [2] three times for the letter "C" then press the right arrow key for the next letter.
- Enter: [1] until you have a blank space (Note: Moving the cursor to the left does not create a space. Spaces must be programmed into the Alpha using the [1] key.
- Enter: [2] for the letter "A" then press the right arrow key for the next letter.
- Enter: [System Reset] The "System Reset" key is the UPPER/lower case toggle.
- Enter: [5] three times for the letter "l" then press the right arrow key for the next letter.
- Enter: [2] for the letter "a" then press the right arrow key for the next letter.
- Enter: [7] twice for the letter "r" then press the right arrow key for the next letter.
- Enter: [6] for the letter "m."
- Enter: [#] Program the next address, program a different address or exit the Programmer's Mode.

7.13 Address 19 - Special Keys

- 0 = Disabled
- 1 = Invisible
- 2 = Steady Audible
- 3 = Pulsing Audible

	DEFAULT	0	0	0
FIRE KEY [A]				
HELP KEY [B]				
PANIC KEY [C]				

- **Disabled:** Special Key not programmed.
- **Invisible:** Special Key programming for no display of alarm on the keypad or on outputs. Not to be used with the Fire Key.
- **Steady Audible:** Special Key programming for steady alarms on outputs and keypad sounders. Will turn on steady unless alarms are already pulsing.
- **Pulsing Audible:** Special Key programming for pulsing alarms on output and keypad sounders.
- **Fire Key [A]:** The emergency key at the bottom left of the keypad entry area is the Fire Key. If programmed, the key will activate a fire alarm when pressed for 2 seconds. May not be programmed as an invisible alarm.
- **Help Key [B]:** The help key at the bottom center of the keypad entry area is the Help Key. If programmed, the key will activate a supplementary or an auxiliary type alarm when pressed for 2 seconds.
- **Panic Key [C]:** The emergency key at the bottom right of the keypad entry area is the Panic Key. If programmed, the key will activate a panic alarm when pressed for 2 seconds; nothing will display at the keypad to indicate an alarm.

7.14 Address 20 - Report Control

NOTE: Closing Reports (and subsequent Open Reports) are only sent when the system is fully armed [PIN] + [ON] Commercial Mode or [#] + [ON] Residential Mode.

	DEFAULT	1	1	1	1
OPENING/CLOSING REPORTS					
0 = Disabled, don't send Opening and Closing Reports					
1 = Always send Opening & Closing Reports, do not send Bypass Reports for any zone bypassed or force armed.					
2 = Always send Opening & Closing Reports and send Bypass Reports for each zone bypassed or forced armed (even if swinger shunted for troubles, but not for interior bypass).					
3 = Only Send Opening & Closing Reports if any zones are bypassed or force armed, and send Bypass Reports for each of these zones (even if swinger shunted for troubles, but not for interior bypass).					
OPEN/CLOSE REPORT ROUTING					
0 = Do Not Report (not allowed for alarm report)					
1 = Phone 1 Only					
2 = Phone 2 Only					
3 = Both Phones 1 and 2					
4 = Phone 1, Phone 2 as backup					
ZONE ALARM, RESTORAL, BYPASS REPORT ROUTING					
0 = Do Not Report (not allowed for alarm report)					
1 = Phone 1 Only					
2 = Phone 2 Only					
3 = Both Phones 1 and 2					
4 = Phone 1, Phone 2 as backup					
ALL OTHER REPORT ROUTING (SYSTEM ROUTING)					
0 = Do Not Report (not allowed for alarm report)					
1 = Phone 1 Only					
2 = Phone 2 Only					
3 = Both Phones 1 and 2					
4 = Phone 1, Phone 2 as backup					

7.15 Address 21 - Phone Number Control

DEFAULT	0	0	0	0	0
Tone/Pulse					
0 = Dial Pulse					
1 = Tone with Auto Switch to Pulse					
2 = Tone with No Switch to Pulse					
Callback for Downloading					
0 = Disabled					
1 = Enabled					
Ring Count					
0 = Disable Answering					
1-F = Number of Rings (Odd numbers Bypass Answering Machine)					
Dialer Delay of 15 Seconds on 24 Hour Alarms					
0 = No Delay					
1 = Delay 24 Hour Alarms					
Dialer Delay of 15 Seconds on Non 24 Hour Alarms					
0 = No Delay					
1 = Delay Non 24 Hour Alarms					

- **Dial Pulse:** If programmed, the panel will dial to phone number 1, 2, or 3 using a pulse format.
- **Dial Tone:** If programmed, the panel will dial to phone number 1, 2, or 3 using a tone format. **Note:** When dialing through PBX systems, program the phone control as tone dial only.
- **Tone with Auto Switch to Pulse:** If programmed, the control panel will try to dial the first digit in tone dial and check to see if the dial tone has been broken. If it has not been broken, it will try to dial again using pulse dial. **Note:** Do not use this setting for PBX systems.
- **Tone with No Switch to Pulse (required for PBX):** This setting will only use Tone dialing. Must be used if the telephone system requires you to dial a number to get an outside line.
- **Callback for Downloading:** When enabled, if an attempt is made to connect to the panel for a remote programming session the panel will hang up and callback the number programmed for Phone 3, Address 44 and 45.
- **Ring Count:** The control panel can be programmed to answer the phone after a selected number of rings for remote programming access.
- **Answering Machine Bypass:** This feature allows the control panel to answer incoming calls when answering machines are used. If the line rings, stops ringing, then rings again within one minute, the panel will seize the phone line on the first ring. To disable this feature, program the control panel to answer on an even number of rings.
- **Dialer Delay:** A Dialer Delay of 15 seconds can be added when reporting burglar alarms, 24-hour burglar alarms, and fire alarms. This delay will help to prevent false alarm reports by giving the user 15 seconds to disarm the system before a report is sent.

7.16 Address 22 - Dial Attempts

01 to 10 01 to 03 Australia	DEFAULT	010
DIAL ATTEMPTS		

7.17 Address 23 - Time Delays

DEFAULT	045	060	004
Entry Delay Time			
0 to 250; Enter Number of Seconds			
Exit Delay Time			
0 to 250; Enter Number of Seconds			
Bell Cutoff Time			
0 to 099; Enter Number of Minutes			

REPORTS

Program locations 24 through 36 are used differently for the particular Phone Format Chosen (see Address 38, 39).

- If a value of 00 is programmed in any of these locations the panel will not send that particular report.
- **Pulsed Formats** (3/1, 3/1E, 3/1 with Parity, 3/1E with Parity, 4/1, and 4/2) will need a unique value placed at each address location. As a recommendation for the pulsed formats, the table in Section 13.1 "Suggested Values" gives a baseline from which to program the various addresses. Please note that each Central Station receiver differs slightly in the report codes that it expects. Therefore, it is best to verify the codes you use with the Central Station. Some of the reports that can be sent, such as OPEN, CLOSE, PARTIAL CLOSE can send an associated User Number as the second digit. To accomplish this, program an F (*5) as the second digit in the program location. When the report is sent the panel will replace the F with the appropriate user number. Pulsed formats 3/1, 3/1 with Parity, and 4/1 need a 0 for the second digit and cannot send user numbers. A non-zero in the second digit location indicates an extended 3/1E or 4/1E format.
- **Fixed Report Formats** (Contact ID, SIA, 4/9) have well defined reports that are sent regardless of the value programmed in the report code location. Any non-zero value programmed in the report code location will send the appropriate report. Refer to Section 13.3 "Values Sent" for a list of reports that are possible to send based on the report program locations.
- **Special Formats** (Personal Dialing Format, Pager) are not recommended for primary reporting. If they are used, Personal Dialing Format could use the same report codes as the Pulsed Formats. Pager has a limitation in that it can't use the Hex values A (*0), B (*1), C (*2), D (*3), E (*4), F (*5). These values can not be passed on to a Numeric Pager. See Section 13.1 "Suggested Values" for some recommended report values for the Pager format.

7.18 Address 24 - Keypad Report

Two Digits, 00 through FF

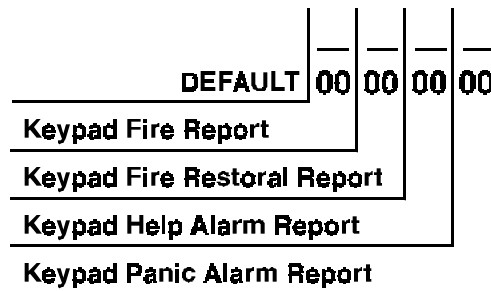

- **Keypad Fire Report:** This report is sent when a fire alarm has been activated using the "A" emergency key.
- **Keypad Fire Restoral Report:** This report is sent when a keypad fire alarm has been restored using the [System Reset] command.
- **Keypad Help Alarm Report:** This report is sent when an help alarm has been activated using the "B" emergency key.
- **Keypad Panic Report:** This report is sent when an emergency alarm has been activated using the "C" emergency key.

7.19 Address 25 - Zone Alarm Report

Two Digits, 00 through FF

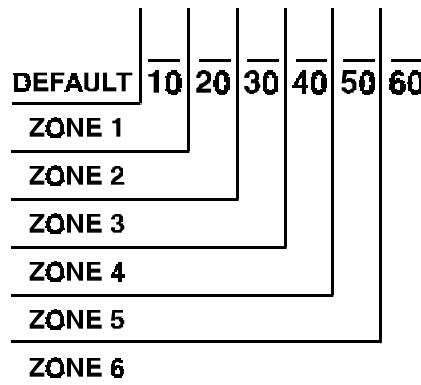

- **Zone Alarm:** An alarm report is sent when a zone alarm occurs. Program this report for any zones where an alarm report is desired. For local zones (no reports), replace the default value with 00.

7.20 Address 26 - Zone Alarm Restoral Report

Two Digits, 00 through FF

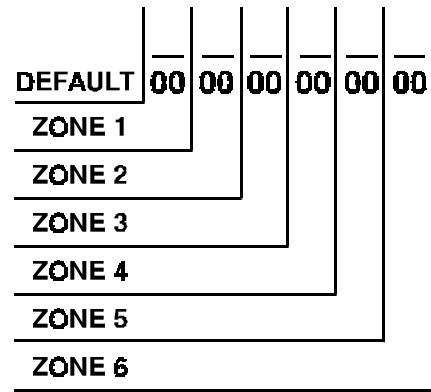

- **Zone Alarm Restoral:** This report is sent when the zone alarm is cleared. Refer to Address 07 for exact point at which report will be sent.

7.21 Address 27 - Zone Trouble Report

Two Digits, 00 through FF

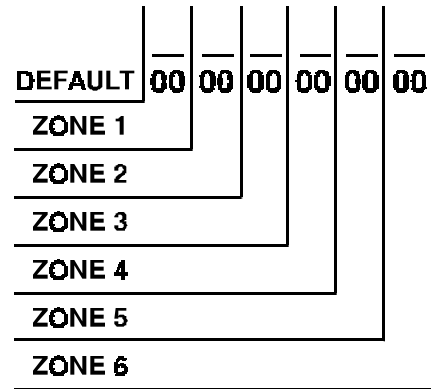

- **Zone Trouble:** This report is sent when a zone trouble condition occurs.

7.22 Address 28 - Zone Trouble Restoral Report

Two Digits, 00 through FF

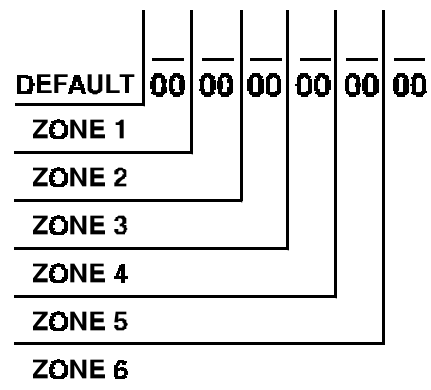

- **Zone Trouble Restoral:** This report is sent when the zone trouble condition is cleared.

7.23 Address 29 - Zone Bypass Report

Two Digits, 00 through FF

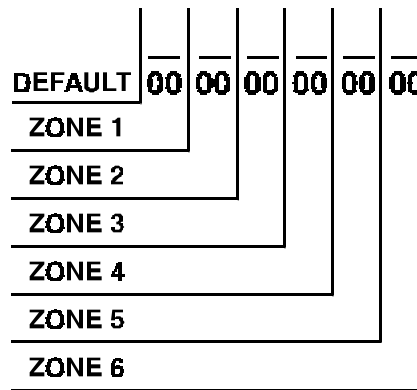

- Zone Bypass Reports are sent with the Closing Report. Address 20 digit 1 (left most digit) must be set for 2 or 3 for these reports. See Section 7.14 - Report Control.

7.24 Address 30 - Zone Bypass Restoral Report

Two Digits, 00 through FF

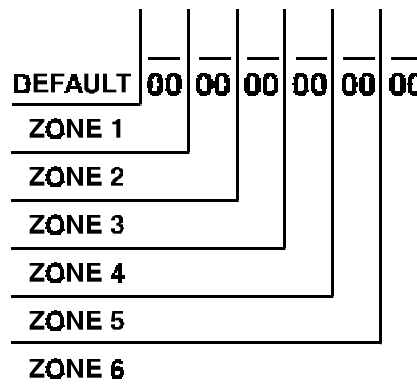

- Zone Bypass Restoral Reports are only sent with an Opening Report. Address 20 digit 1 (left most digit) must be set for 2 or 3 for these reports. See Section 7.14 - Report Control.

7.25 Address 31 - Open/Close Duress Report

Two Digits, 00 through FF (If second digit is F, the user code is substituted) NOTE: 3/1, 3/1 with Parity, and 4/1 will not send a user number.

NOTE: If "Quick Arm" or Residential Mode is used, User #1 will be reported in closing reports.

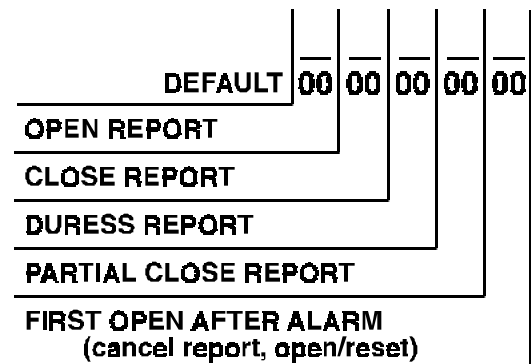

- **Open:** This report is sent when the system has been disarmed. In Contact ID, SIA or 4/9 formats, the user number for the person who disarmed the system will be sent with this report. To send the user number along with an Open Report in other formats, program the extended digit of the report as F ([*] [5]). The Open Report will only be sent if a Close Report was sent previously.
- **Close:** This report is sent when the system has been armed. In Contact ID, SIA or 4/9 formats, the user number for the person who armed the system will be sent with this report. To send the user number along with a Close Report in other formats, program the extended digit of the report as F ([*] [5]).
- **Duress:** This report is sent when the system is disarmed using a duress code. The user number will not be sent along with this report.
- **Partial Close:** This report is sent when the system is armed partially, or force armed.
- **First Open After Alarm:** This report is sent when the system is disarmed after an alarm has occurred. It will also be sent if the system is already disarmed and a user number is entered to silence a 24-hour or fire zone.

7.26 Address 32 - Battery, AC Report

Two Digits, 00 through FF

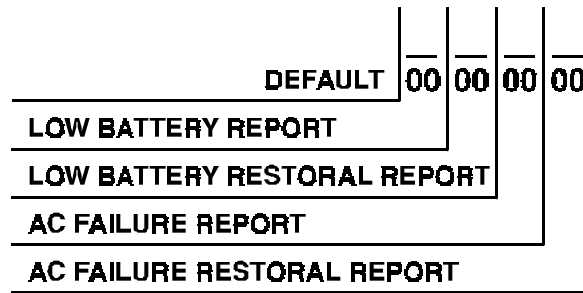

- **Low Battery Report:** This report is sent when a low battery condition occurs.
- **Low Battery Restoral Report:** This report is sent when a low battery condition restores.
- **AC Failure Report:** This report is sent after an AC failure condition occurs. AC failure reports will only be sent along with other reports if Address 50 is set to "000." Otherwise reports will be sent after the delay set in Address 50.
- **AC Failure Restoral Report:** This report is only sent along with other reports if Address 50 is set to "000." Otherwise reports will be sent after the delay set in Address 50.

7.27 Address 33 - Programming Report

Two Digits, 00 through FF (uses system report routing)

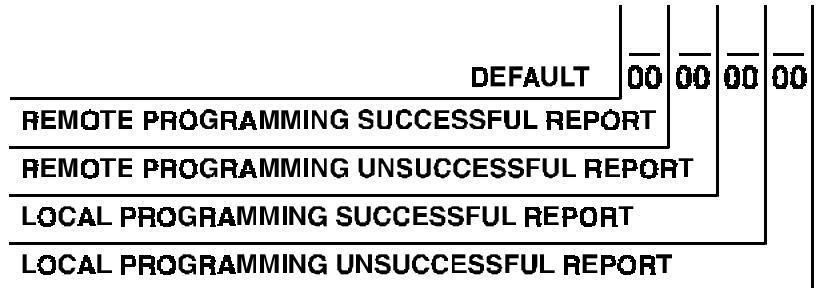

- **Remote Programming Successful:** This report is sent after a Remote Programming session, if the session was terminated properly.
- **Remote Programming Unsuccessful:** This report is sent after a Remote Programming session, if some error has occurred or the session did not terminate properly.
- **Local Programming Successful:** This report is sent when local programmer's mode is exited and there has been no error associated with the programming.

7.28 Address 34 - System Report

Two Digits, 00 through FF (uses system report routing)

Note: The Auxillary Power Fault Report is only available on DS7060 panels with auxillary power fuses. Panels without fuses will send a System Trouble Report if problems occur with the auxillary power.

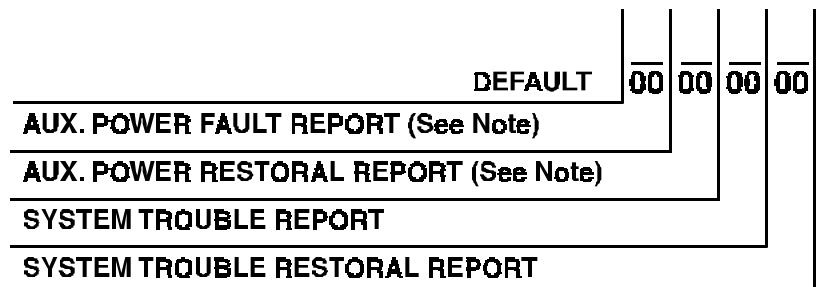

- **System Trouble:** This report is sent when a control trouble condition occurs.
- **System Trouble Restoral:** This report is sent when all system trouble conditions restore.

7.29 Address 35 - Exit Error, Recent Closing, Comm. Failure Report

Two digits, 00 through FF, (if second digit is F, the user code is substituted except if 3/1, 3/1 with Parity, or 4/1 format is used).

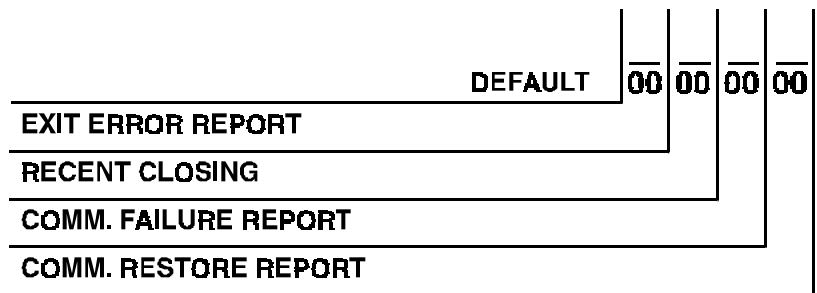

- **Exit Error:** This report is sent if an exit error occurs. An exit error occurs when an entry/exit zone is still violated at the end of the exit delay. If this happens, the entry delay will begin. If the system is not disarmed before the entry delay expires, an alarm report for the effected zone will be sent and the Exit Error Report will be sent.
- **Recent Closing:** This report is sent, along with any alarm reports, when there is an alarm within the first five minutes after the system has been armed.
- **Comm. Failure Report:** This report is sent after the programmed number of communicator attempts. Refer to Address 22 - Dial Attempts.
- **Comm. Restore Report:** This report is sent after there has been a communicator failure. Retries will occur after 30 minutes, then every 24 hours or when a new event occurs. When the next successful communicator attempt occurs, this report will be included.

7.30 Address 36 - Test Reports, System Test

Two Digits, 00 through FF

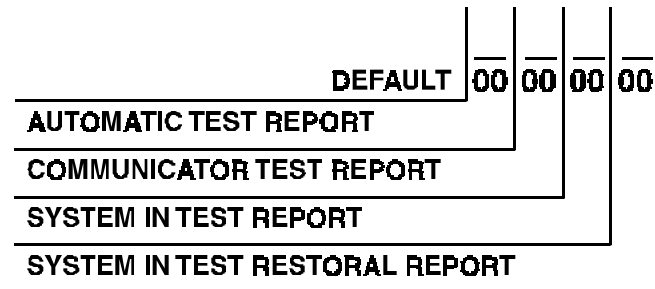

- **Automatic Test Report:** This report is sent at fixed intervals determined by programming Address 48 - Automatic Test Report Interval. By default, the panel will send the first automatic report 12 hours after the panel has been powered up, and from that point on, it will follow the interval selected by Address 48. The time before the first Automatic test report is sent can be adjusted between 1 and 24 hours after the panel has been powered up by setting Address 49 - Hours to First Auto Test Report.
- **Communicator Test Report:** This report is sent as a result of initiating a Communicator Test, a PIN + [#] [8] [2] command sequence. Requires that Addresses 37 "Account Code", 38 "Phone # 1 Format" and 40 "Phone #1 be programmed.
- **System Test:** This report is sent when a system test has been started using the [#] [8] [1] key sequence.
- **System Test Restoral:** This report is sent when the system test [#] [8] [1] has been completed or has timed-out.

7.31 Address 37 - Account Codes

4 Digits, 0000 through FFFF

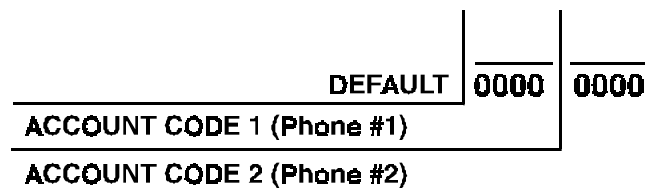

NOTE: If the account code is "0000" no reports will be sent.

NOTE: If a 3-digit code is required (when using pulse formats 3/1 and 3/1 with Parity) the fourth digit must be 0. For example: If the account code is 121, program 1210 in the account code address.

NOTE: If using personal dialing or Pager format an account code is still required, even if the system does not report to a central station. The account code must use digits 0-9. A-F cannot be displayed on a pager.

7.32 Address 38 - Phone #1 Format

Address 39 - Phone #2 Format

PHONE FORMAT

- 0 = Disabled
- 1 = 3/1
- 2 = 3/1E (Extended Reporting)
- 3 = 3/1 with Parity
- 4 = 3/1E with Parity
- 5 = 4/1
- 6 = 4/2
- 8 = SIA (110 Baud)
- 9 = Contact ID
- A = SIA (300 Baud)
- C = Personal Dialing
- D = 4/9
- F = Pager

SPEED

- 0 = 10 pps
- 1 = 20 pps
- 2 = 40 pps

DATA/ACKNOWLEDGE TONES

- 0 = 1900 data - 1400 ack
- 1 = 1800 data - 2300 ack

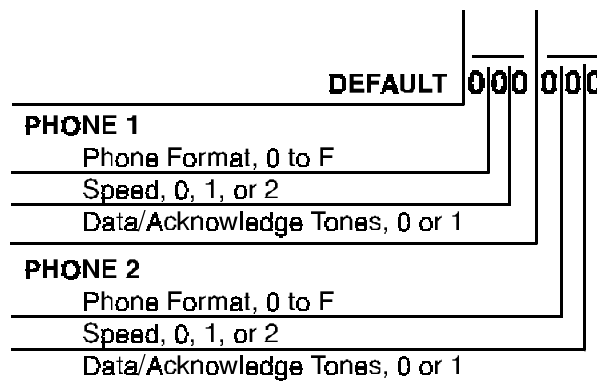

7.33 Address 40-41 Phone #1 (Reporting)

Address 42-43 Phone #2 (Reporting)

Address 44-45 Phone #3 (Remote Programming)

Address 40 Phone #1 (digits 1-16): _____

Address 41 Phone #1 (digits 17-32): _____

Address 42 Phone #2 (digits 1-16): _____

Address 43 Phone #2 (digits 17-32): _____

Address 44 Phone #3 (digits 1-16): _____

Address 45 Phone #3 (digits 17-32): _____

- NOTE:**
- To dial the [*] character, enter *1 (The [*] character is sent as "1" "1" when pulse dialing). The letter "B" will be displayed.
 - To dial the [#] character, enter *2 (The [#] character is only valid when tone dialing). The letter "C" will be displayed.
 - To input a three second delay, enter *3. The letter "D" will be displayed.
 - To wait for the dial tone, enter *4 in the first digit. The letter "E" will be displayed.
 - To disable a phone number, enter *5 in the first digit. The underscore "_" will be displayed.
 - To delete the phone number from the display window, enter *5 in all digits.

7.34 Address 46 - Programmer & Master Codes

See the Users Guide P/N 29955 for more information on Personal Identification Numbers.

Four Digits each code: 0000 through 9999

* User Codes 2 through 15 are programmed from Master Code Programming Mode

Note: The display will only show ***** and give no visual indication of the codes being entered. You cannot read back the codes.

DEFAULT	9876	1234
PROGRAMMER'S CODE		
MASTER CODE		

7.35 Address 47 - Default EEPROM

0 = No Action

1 = Load Factory Default

DEFAULT	0
DEFAULT PROGRAM	

CAUTION: Entering a [1] in Address 47 will erase all prior programming.

7.36 Address 48 - Automatic Test Report Interval

0 = None

1 = Callout Daily

2 = Callout every 7 days

3 = Callout every 28 days

DEFAULT	0
TEST REPORT INTERVAL	

7.37 Address 49 - Hours to First Auto Test Report

001-023 hours

DEFAULT	012
HOURS TO 1ST REPORT	

- Set this value to the number of hours from the time the panel was powered up for the first report. Example: If the panel was powered up at 2 PM and you want test reports at 3 AM, set to [0 1 3] (2 PM + 13 hours = 3 AM). If not set, the first report will be sent 12 hours after panel power up.

7.38 Address 50 - AC Failure Report Delay

000 to 250; Enter Number of Minutes

DEFAULT	000
AC FAILURE REPORT DELAY	

- Address 32 must be programmed for this report.

NOTE: If AC power should restore before the "AC Failure Report" time, no AC Failure Report will be sent.

7.39 Address 51 - Keypad Language Programming

0 = English

1 = French

2 = Spanish

Note: Selections 1 and 2 may vary by country.

DEFAULT	0
KEYPAD LANGUAGE DISPLAY	

8.0 INSTALLATION GUIDE FOR U. L. LISTED SYSTEMS

8.1 DS7060 U. L. Listings

- Household Fire Alarm, U. L. Standard UL985
- Household Burglary Alarm, U. L. Standard UL1023
- Police Station Connection Grades AA and A, U. L. Standard UL365
- Central Station Burglary Alarm Grades AA, A, B, and C, U. L. Standard UL1610

The control panel has not been investigated to the requirements of UL294.

The control panel should be installed in accordance with U. L. Standard UL681, Installation and Classification of Mercantile and Bank Burglar Alarm Systems, or U. L. Standard UL1641, Installation and Classification of Residential Burglar Alarm Systems. It should also be installed in accordance with NFPA 72 for Household installations.

The following table shows the DS7060 system configuration for the various types of fire and burglar alarm service for which the products are U. L. Listed.

PRODUCT	U. L. APPLICATION					
	CSB-A	CSB-B/C	LB-A	PSCB-D-A	PSCB-RF-A	HF/B
DS7060	R	R	R	R	R	R
Standard Enclosure	n/a	n/a	n/a	n/a	n/a	1
Attack Enclosure	R	R	R	R	R	1
DS7443	2	2	2	2	2	2
DS7445	2	2	2	2	2	2
DS7447	2	2	2	2	2	2
Spectrum PAL200	R	n/a	n/a	n/a	R	n/a
AB-12 Bell/Housing	R	R	R	R	R	n/a

Key to Application Codes

CSB-A	Central Station Burglary, grades AA and A
CSB-B/C	Central Station Burglary, grades B and C
LB-A	Local Burglary, grade A
PSCB-D-A	Police Station Connected Burglary w/DACT, grade A
PSCB-RF-A	Police Station Connected Burglary w/Radio, grades AA and A
HF/B	Household (residential) Fire and Burglary

Key to Application Codes

R	Required
n/a	Not Applicable
1	Standard or attack enclosure may be used.
2	Any keypad may be used, at least one keypad is required.

8.2 Installation Considerations

- Failure to install and program the control in accordance with the requirements in this section voids the listing mark of Underwriters Laboratories, Inc.
- The standby battery capacity is 7 AH @ 12 VDC.
- The total nominal current must not exceed 750 mA when on standby or in alarm.
- The control must be mounted indoors and within the protected area.
- Enclosure tamper switches (if used) must be connected to a 24-hour zone.
- Grounding must be in accordance with article 250 of the NEC (NFPA 70).
- At least one U. L. Listed keypad with zone display must be connected.
- Zones must be connected to U. L. Listed, compatible devices.
- 50 Hz AC input cannot be used in U. L. Listed Requirements.
- The ground wire provided with the enclosure must be connected between the "Earth GND" connection on the control and the enclosure tab.
- The keypad panic alarm output must follow the corresponding zone's programming (e.g. fire = pulsing [or steady if not a combination],

- burglary = steady). In all cases, the special emergency keys must be silent.
- The ground start feature shall not be programmed.
 - Compatible keypads are Detection Systems' DS7443, DS7445, and DS7447.
 - The Pager format must not be employed.
 - The alarm output must not be delayed.

8.3 Programming the DS7060

When used in U. L. Listed Requirements, the control must conform to certain programming requirements. The following is a list of the required program entries and required accessories for specific U. L. Listed Requirements.

Household Fire Alarm (using Digital Alarm Communicator Transmitter with local bell)

The control must be installed in accordance with NFPA 72.

Required Accessories:

- At least one Detection Systems' model DS250 Series 4 wire smoke detector with an MB4W Series 4 wire base, or another Listed 4 wire smoke detector.
- One Wheelock 46T-G10-12 bell or 34T-12 horn (will provide 85dB for UL985 and NFPA 72 requirements; other Listed compatible devices with a voltage range of 10.2 to 14.0 V may be used) is required for this application and must be installed inside the protected area.
- The standard control enclosure can be used.
- At least one DS7443, DS7445 or DS7447 Keypad must be used.
- Four-wire detectors must be used with Listed power supervision devices. A compatible Listed four-wire detector is the Detection Systems, Inc. DS250 in an MB4W base. A compatible Listed EOL relay is the Detection Systems, Inc. EOL200.
- All zones must be used with the EOL resistor (P/N 25899) provided.

A. Report Programming:

- Fire Zone Report must be programmed.
- Low Battery Report (Program Address 32) must be programmed.
- AC Failure Report (Program Address 32) must be programmed.

B. Timer Programming:

- Bell Cutoff Time (Program Address 23) must be programmed for not less than 4 minutes.

C. Zone Programming:

- For household fire installations only, the output signal may be pulsed or steady. For a combination system, see the selection below on alarm output programming. Fire zones must be programmed (Address 03 - Zone Action) for alarm on short, trouble on open (value = 1).

D. Alarm Output Programming:

- Program fire zone outputs as pulsed, burglar zone outputs as steady (Address 04).

E. General Control Programming:

- Program Address 10 must be programmed for Closing Ringback Enabled.
- Program Address 10 must be programmed for 60 Hz.
- Program Address 10 must be programmed for Swinger Shunt disabled.
- Program Address 10 must be programmed as Force Arming disabled.
- Program Address 10 must be programmed for Auto Bypass disabled.

Grade A Household Burglary Alarm (using Digital Alarm Communicator Transmitter with local bell)

The control must be installed in accordance with U. L. Standard UL1641.

Required Accessories:

- At least one Wheelock 46T-G10-12 bell or 34T-12 horn (other Listed compatible devices with a voltage range of 10.2 to 14.0 V may be used) is required for this application.
- The standard DS7060 enclosure can be used.

A. Report Programming:

- Burglar Zone Reports must be programmed for those zones used.
- Low Battery Report (Program Address 32) must be programmed.
- AC Failure Report (Program Address 32) must be programmed.

B. Timer Programming:

- Bell Cutoff Time (Program Address 23) must be programmed for not less than 4 minutes.

- Entry Delay Timer (Program Address 23) must be programmed for not longer than 60 seconds.
- Exit Delay Timer (Program Address 23) must be programmed for not longer than 45 seconds.

C. General Control Programming:

- Program Address 10 must be programmed for Swinger Shunt disabled.
- Program Address 10 must be programmed as Force Arming disabled.

D. Alarm Output Programming:

- Program Address 08 must be programmed as [X] [X] [8] (follow burglar and fire alarm).
- Program Address 04 must be programmed as and burglar zones 2 (steady) and fire zones 3 (pulsing).

NOTE: In a system that includes both fire alarm and burglar alarm devices, the system must produce distinct sounds for fire and burglar alarm conditions either by using different indicating appliances or by using distinct cadences for the same appliance.

Local Burglary Alarm

The control must be installed in accordance with U. L. Standards UL681 and UL609 for all grades of service.

Grade A Installations using Digital Alarm Communicator Transmitter with local bell

Required Accessories:

- The control must be mounted in the Detection Systems' model 7060CC enclosure with a cover actuated tamper switch installed.
- The Ademco Model AB-12 bell/housing (see Section 8.4).

1. Report Programming:

- Burglar Zone Reports must be programmed for those zones used.
- Low Battery Report (Program Address 32) must be programmed.
- AC Failure Report (Program Address 32) must be programmed.
- Open Report (Program Address 31) must be programmed.
- Close Report (Program Address 31) must be programmed.
- 24-Hour Check-In Reports (Program Address 36) must be programmed.

2. Timer Programming:

- Bell Cutoff Times (Program Address 23) must be programmed for not less than 15 minutes.
- Entry, Exit Delay Times (Program Addresses 23) must be programmed for not longer than 60 seconds.

3. General Control Programming:

- Must be programmed for Swinger Shunts disabled, Closing Ringback disabled, 60 Hz, Auto Bypass disabled and Force Arming disabled (Program Address 10).

4. Zone Programming:

- The Burglar alarm output signal, Address 04, (whether pulsed or steady) must be different from the Fire alarm signal.

5. Alarm Output Programming:

- Program Address 08 must be programmed as [X] [X] [8].

Police Station Connection

The control must be installed in accordance with U. L. Standards UL611 and UL681 for all grades of service.

Grades AA and A Installations using the Applied Spectrum PAL200 and the DACT

Required Accessories:

- The control must be mounted in the Detection Systems' model 7060CC enclosure with a cover actuated tamper switch installed.
- The Applied Spectrum PAL200.
- The Applied Spectrum PAL200 must be installed within 3 feet of the control and the wiring from the Applied Spectrum PAL200 to the control must be in conduit.
- The Applied Spectrum PAL200 inputs should be connected to the alarm outputs (the active alarm sounder output may be used).

1. Report Programming:

Programming shall be enabled to allow all alarm signals to be transmitted via the DACT and PAL200.

- Burglar Zone Reports are not required since the alarms are transmitted over the PAL200.
- Low Battery Report (Program Address 32) must be programmed.
- AC Failure Report (Program Address 32) must be programmed.
- Open Report (Program Address 31) must be programmed.
- Close Report (Program Address 31) must be programmed.
- 24-Hour Check-In Reports (Program Address 36) must be programmed.

2. Timer Programming:
 - Entry, Exit Delay Times (Program Address 23) must be programmed for not longer than 60 seconds.
3. General Control Programming:
 - Must be programmed for Swinger Shunts disabled, Closing Ringback disabled, and Force Arming disabled (Program Address 10).
4. Zone Programming:
 - The Burglar alarm output signal, Address 04, (whether pulsed or steady) must be different from the Fire alarm signal.
5. Alarm Output Programming:
 - Program Address 08 must be programmed as [X] [X] [8].

Grade A Installations using Digital Alarm Communicator Transmitter with local bell

Required Accessories:

- The control must be mounted in the Detection Systems' model 7060CC enclosure with a cover actuated tamper switch installed.
- The Ademco Model AB-12 bell/housing (see Section 8.4).

1. Report Programming:
 - Burglar Zone Reports must be programmed for those zones used.
 - Low Battery Report (Program Address 32) must be programmed.
 - AC Failure Report (Program Address 32) must be programmed.
 - Open Report (Program Address 31) must be programmed.
 - Close Report (Program Address 31) must be programmed.
 - Automatic Test Reports (Program Address 36) must be programmed.
2. Timer Programming:
 - Bell Cutoff Times (Program Address 23) must be programmed for not less than 15 minutes.
 - Entry, Exit Delay Times (Program Address 23) must be programmed for not longer than 60 seconds.
3. General Control Programming:
 - Must be programmed for Swinger Shunts disabled, Closing Ringback disabled, 60 Hz, Auto Bypass disabled and Force Arming disabled (Program Address 10).
4. Zone Programming:
 - The Burglar alarm output signal, Address 04, (whether pulsed or steady) must be different from the Fire alarm signal.
5. Alarm Output Programming:
 - Program Address 08 must be programmed as [X] [X] [8].

Central Station Burglary Alarm

The control must be installed in accordance with U. L. Standards UL611 and UL681 for all grades of service.

Grades AA and A Installations using the Applied Spectrum PAL200 and the DACT

Required Accessories:

- The control must be mounted in the Detection Systems' model 7060CC enclosure with a cover actuated tamper switch installed.
- The Applied Spectrum PAL200.
- The Applied Spectrum PAL200 must be installed within 3 feet of the control and the wiring from the Applied Spectrum PAL200 to the control must be in conduit.
- The Applied Spectrum PAL200 inputs should be connected to the alarm outputs (the active alarm sounder output may be used).

1. Report Programming:

Programming shall be enabled to allow all alarm signals to be transmitted via the DACT and PAL200.

 - Burglar Zone Reports are not required since the alarms are transmitted over the PAL200.
 - Low Battery Report (Program Address 32) must be programmed.
 - AC Failure Report (Program Address 32) must be programmed.
 - Open Report (Program Address 31) must be programmed.
 - Close Report (Program Address 31) must be programmed.
 - Automatic Test Reports (Program Addresses 36) be programmed.
2. Timer Programming:
 - Entry, Exit Delay Times (Program Address 23) must be programmed for not longer than 60 seconds.

3. General Control Programming:

- Must be programmed for Swinger Shunts disabled, Closing Ringback disabled, 60 Hz, Auto Bypass disabled and Force Arming disabled (Program Address 10).

4. Zone Programming:

- The Burglar alarm output signal, Address 04, (whether pulsed or steady) must be different from the Fire alarm signal.

5. Alarm Output Programming:

- Program Address 08 must be programmed as [X] [X] [8].

Note: Grade AA requires central station polls of the protected premise unit once every 5 minutes during armed periods and randomly during disarmed periods. A central station poll once every 24 hours is acceptable for Grade A installations.

Grade B Installations using Digital Alarm Communicator Transmitter with local bell

Required Accessories:

- The control must be mounted in the Detection Systems' model 7060CC enclosure with a cover actuated tamper switch installed.
- The Ademco Model AB-12 bell/housing (see Section 8.4).

1. Report Programming:

- Burglar Zone Reports must be programmed for those zones used.
- Low Battery Report (Program Address 32) must be programmed.
- AC Failure Report (Program Address 32) must be programmed.
- Open Report (Program Address 31) must be programmed.
- Close Report (Program Address 31) must be programmed.
- Automatic Test Reports (Program Address 36) must be programmed.

2. Timer Programming:

- Bell Cutoff Times (Program Address 23) must be programmed for not less than 15 minutes.
- Entry, Exit Delay Times (Program Address 23) must be programmed for not longer than 60 seconds.

3. General Control Programming:

- Must be programmed for Swinger Shunts disabled, Closing Ringback disabled, 60 Hz, Auto Bypass disabled and Force Arming disabled (Program Address 10).

4. Zone Programming:

- The Burglar alarm output signal, Address 04 (whether pulsed or steady) must be different from the Fire alarm signal.

5. Alarm Output Programming:

- Program Address 08 must be programmed as [X] [X] [8].

Grade C Installations using Digital Alarm Communicator Transmitter only

Required Accessories:

- The control must be mounted in the Detection Systems' model 7060CC enclosure with a cover actuated tamper switch installed.

1. Report Programming:

- Burglar Zone Reports must be programmed for those zones used.
- Low Battery Report (Program Address 32) must be programmed.
- AC Failure Report (Program Address 32) must be programmed.
- Open Report (Program Address 31) must be programmed.
- Close Report (Program Address 31) must be programmed.
- Automatic Test Report (Program Address 36) must be programmed.

2. Timer Programming:

- Entry, Exit Delay Times (Program Address 23) must be programmed for not longer than 60 seconds.

3. General Control Programming:

- Must be programmed for Swinger Shunts disabled, Closing Ringback disabled, 60 Hz, Auto Bypass disabled and Force Arming disabled (Program Address 10).

4. Zone Programming:

- The Burglar alarm output signal, Address 04, (whether pulsed or steady) must be different from the Fire alarm signal.

5. Alarm Output Programming:

- Program Address 08 must be programmed as [X] [X] [8].

8.4 Wiring and Programming Information for Installations Using the Ademco AB-12 Bell/Housing

ADEMCO AB-12 BELL/HOUSING

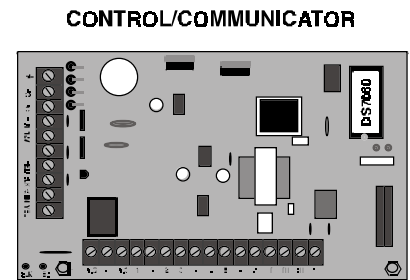
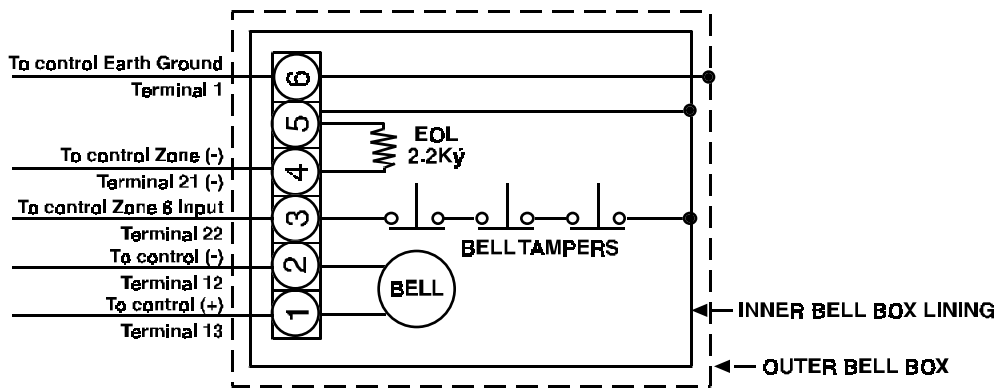

- 1) Disconnect the wire jumper from terminal 4 to the inner housing of the Bell Box.
- 2) Connect wiring between the control and Bell Box as shown above.
- 3) Program Zone 6 as a 24-hour zone. (Program Address 01 must be programmed as [2]).
- 4) Programmable Output 3 must be programmed. See Address 08 - Outputs.

9.0 FCC COMPLIANCE NOTICE

This equipment has been tested and found to comply with the limits for a Class B digital device, pursuant to Part 15 of the FCC Rules. These limits are designed to provide reasonable protection against harmful interference in a residential installation. This equipment generates, uses, and can radiate radio frequency energy and if not installed and used in accordance with the instructions, may cause harmful interference to radio communications. However, there is no guarantee that interference will not occur in a particular installation. If this equipment does cause harmful interference to radio or television reception, which can be determined by turning the equipment off and on, the user is encouraged to try to correct the interference by one or more of the following measures:

- Reorient or relocate the receiving antenna.
- Increase the separation between the equipment and the receiver.
- Connect the equipment into an outlet on a circuit different from that of the receiver.
- Consult the dealer or an experienced radio/TV technician for help.

10.0 FCC PHONE CONNECTION NOTICE TO USERS

This control complies with Part 68 of the FCC rules.

On the inside of the enclosure is a label that contains, among other information, the FCC Registration Number and the Ringer Equivalence Number (REN) for this equipment. You must, upon request, provide this information to your local telephone company. The Ringer Equivalence Number of this device 0.1 B.

The REN is useful to determine the quantity of devices that you may connect to your telephone line and still have all of those devices ring when your telephone number is called. In most, but not all areas, the sum of the REN's of all devices connected to one line should not exceed five (5.0). To be certain of the number of devices that you may connect to your line, you may want to contact your local telephone company to determine the maximum REN for your local calling area.

This equipment may not be used on coin service provided by the telephone company. This control should not be connected to party lines.

Should this equipment cause harm to the telephone network, the telephone company may discontinue your service temporarily. If possible, they will notify you in advance. But if advance notice isn't practical, you will be notified as soon as possible. You will be informed of your right to file a complaint with the FCC. The telephone company may make changes in its facilities, equipment, operations, or procedures, that could affect the proper functioning of your equipment. If they do, you will be notified in advance to give you an opportunity to maintain uninterrupted telephone service.

If you experience trouble with this equipment, please contact the manufacturer for information on obtaining service or repairs.

The telephone company may ask that you disconnect this equipment from the network until the problem has been corrected or until you are sure that the equipment is not malfunctioning. The repairs to this equipment must be made by the manufacturer and not by the user.

To guard against accidental disconnection, there is ample room to mount the Telco jack to the inside of the Control cabinet.

The operation of this Control may also be affected if events such as accidents or acts of God cause an interruption in telephone service.

11.0 CANADIAN DEPARTMENT OF COMMUNICATIONS

11.1 General Installation Requirements

Notice: The Canadian Department of Communications label identifies certified equipment. This certification means that the equipment meets certain telecommunications network, protective, operational, and safety requirements. The Department does not guarantee the equipment will operate to the user's satisfaction.

Before installing this equipment, users should ensure that it is permissible to be connected to the facilities of the local telecommunications company. The equipment must also be installed using an acceptable method of connection. In some cases, the company's inside wiring associated with a single line individual service may be extended by means of a certified connector assembly (telephone extension cord). The customer should be aware that compliance with the above conditions may not prevent degradation of service in some situations.

Repairs to certified equipment should be made by an authorized Canadian maintenance facility designated by the supplier. Any repairs or alterations made by the user to this equipment, or equipment malfunctions, may give the telecommunications company cause to request the user to disconnect the equipment.

Users should ensure, for their own protection, that the electrical ground connections of the power utility, telephone lines, and internal metallic water pipe system, if present, are connected together. This precaution may be particularly important in rural areas.

CAUTION: Users should not attempt to make such connections themselves, but should contact the appropriate electric inspection authority, or electrician, as appropriate.

11.2 Terminal Requirements

The Load Number (LN) assigned to each terminal device denotes the percentage of the total load to be connected to a telephone loop which is used by the device, to prevent overloading. The termination on a loop may consist of any combination of devices subject only to the requirement that the total of the Load Numbers of all the devices does not exceed 100. The Load Number of the DS7060 is 2.

11.3 RFI Requirements

This Class A digital apparatus meets all requirements of the Canadian Interference-Causing Equipment Regulations. [Cet appareil numérique de la classe A respecte toutes les exigences du Règlement sur le matériel brouilleur du Canada].

12.0 FOR INSTALLATIONS IN NEW ZEALAND

Two-Wire Connection: The operation of this equipment on the same line as telephones or other equipment with audible warning devices or automatic ring detectors will give rise to bell tinkle or noise and may cause false tripping of the ring detector. Should such problems occur, the user is not to contact Telecom Faults Service.

"This equipment does not fully meet Telecom's impedance requirements. Performance limitations may occur when used in conjunction with some parts of the network. Telecom will accept no responsibility should difficulties arise under such circumstances."

13.0 REPORT PROGRAMMING

13.1 Suggested Values

Personal Dialing Format

This is a 2 pulse per second (PPS) 0/2 (no account code/2 report event digits) format intended for manual reception, i.e. the panel will call a phone number where a person is expected to answer. After a call is made, the panel will start sending the first report. If the report was a "Communicator Test" and Program Address 36 had a value of 00850000 the person answering the phone will hear 8 pulses followed by a 1 second delay, then 5 pulses followed by a 3 second delay. This sequence will repeat for 60 seconds per call. After 60 seconds the panel will hang up and call again making a total of three calls of 60 seconds duration each. After three calls, the panel considers this a successful transmission of one report. If any reports still remain to be sent, they will be sent in the same manner.

A way to expedite this report process would be to provide an acknowledge to the panel that the report was heard and understood by the receiving party. When an acknowledge is provided, the panel will start sending the next report or hang up if no reports remain. To provide an acknowledge, press the 1 key of the telephone keypad during the 3 second delay of the report transmission. This "Acknowledge Feature" is an enhancement that will allow the panel to send all reports in one call.

It is recommended that the reporting values for this format be the same as the Pager Format.

13.2 Pager Format

The Pager format allows the control panel to dial a digital pager and leave a numeric message which includes an account ID and report type. The telephone number is dialed when a report is available. At the completion of the telephone dialing, a fixed time delay equal to 10 seconds occurs. This delay allows time to connect with the pager service, while skipping over any voice announcement. When the delay has ended, the numeric message is sent. This message includes the account number followed by up to 5 reports. If a delay time greater than 10 seconds is required, increments of 3 seconds can be added by programming the "*"3" character (3 second delay) at the end of the phone number in address 40 or 42.

For example, if you call pager number 123-4567 and it takes 20 seconds after you finished dialing before you are allowed to enter the message, the following digits should be programmed in address 40: 1 2 3 4 5 6 7 *3 *3 *3 *3. This will give you an overall delay of 22 seconds.

Note: Some paging systems do not have a voice announcement and expect data entry within the first three to five seconds. Due to the built in 10 second communicator delay, the paging system may hang up before the reports are sent. If this problem occurs, contact your pager provider about adding a voice announcement or a delay.

Note: For Pager format, it is not advisable to use the HEX character values (*0 = A, *1 = B, *2 = C, *3 = D, *4 = E, *5 = F) in the report programming addresses 24 through 36 or as part of the Account Code (address 37). These characters could cause unpredictable results when sent to a pager system that only expects numeric characters between 0-9. This is the reason that this format will not allow an associated user number with an open and close report. If using a remote programming program, such as WDSRP, do not use 0 as a reporting or account code digit as the remote programmer programs 0 as *0 (A).

Note: The Pager format is an open-loop format which has no acknowledge tone. There is no indication at the control panel that the signal has been sent. Therefore, the Pager format is not recommended as the primary communication method.

For Additional Information, see Programming Addresses 24-36 and 40-42.

The following are recommended programming values for addresses 24 through 36 when using the Pager format.

Warning: If sending reports to both a pager and to a central station, **Do Not** use a 0 as the reporting digit as it will disable the report to the central station.

Personal Dialing and Pager Format (suggested values)

	REPORT	RESTORAL	TROUBLE	BYPASS	BYPASS RESTORAL
ZONE 1	1 1	2 1	4 1	3 1	5 1
ZONE 2	1 2	2 2	4 2	3 2	5 2
ZONE 3	1 3	2 3	4 3	3 3	5 3
ZONE 4	1 4	2 4	4 4	3 4	5 4
ZONE 5	1 5	2 5	4 5	3 5	5 5
ZONE 6	1 6	2 6	4 6	3 6	5 6
LOW BATTERY	8 6	7 6			
AC FAIL	8 1	7 1			
SYSTEM TROUBLE	6 2	7 2			
SYSTEM TEST	6 5	7 5			
KEYPAD FIRE	9 9	9 1			
FUSE FAULT	6 6	7 6			

	REPORT
OPEN	8 1
CLOSE	8 2
PARTIAL CLOSE	8 3
FIRST OPEN AFTER ALARM	8 4
AUTOMATIC COMM. TEST	8 5
MANUAL COMM. TEST	8 6
EXIT ERROR	8 7
RECENT CLOSING	8 8

	REPORT SUCCESSFUL	REPORT UNSUCCESSFUL
REMOTE PROGRAM	6 3	7 3
LOCAL PROGRAM	6 4	7 4
KEYPAD EMERGENCY	9 2	
KEYPAD PANIC	9 3	
DURESS	9 4	

4/2 Format (suggested values)

	REPORT	RESTORAL	TROUBLE	BYPASS	BYPASS RESTORAL
ZONE 1	A 1	2 1	6 1	D 1	E 1
ZONE 2	A 2	2 2	6 2	D 2	E 2
ZONE 3	A 3	2 3	6 3	D 3	E 3
ZONE 4	A 4	2 4	6 4	D 4	E 4
ZONE 5	A 5	2 5	6 5	D 5	E 5
ZONE 6	A 6	2 6	6 6	D 6	E 6
LOW BATTERY	F 9	E 9			
AC FAIL	F A	E A			
SYSTEM TROUBLE	F D	E D			
SYSTEM TEST	F 1	E 1			
KEYPAD FIRE	A A	2 A			
COMM. TROUBLE	F B	E B			
FUSE FAULT	F 5	E 5			

	REPORT
OPEN	B F
CLOSE	C F
PARTIAL CLOSE	4 F
FIRST OPEN AFTER ALARM	3 8
AUTOMATIC COMM. TEST	3 A
MANUAL COMM. TEST	6 5
EXIT ERROR	8 6
RECENT CLOSING	8 7

	REPORT SUCCESSFUL	REPORT UNSUCCESSFUL
REMOTE PROGRAM	0 0	0 0
LOCAL PROGRAM	0 0	0 0
KEYPAD EMERGENCY	1 6	
KEYPAD PANIC	A A	
DURESS	1 5	

13.3 Values Sent

High Speed 4/9 Format

NOTE: These values are shown for information only. They cannot be changed by programming.

Event Data codes indicate the following:

1 = new event, 3 = restoral, 5 = normal, 6 = event still exists.

The placement of these codes in the Event Data column indicates the status of the corresponding zone (1-6).

Event Type identifiers indicate the following:

1 = Panic, 2 = Opening, 3 = Bypass, 4 = Closing, 5 = Trouble, 6 = System Info., 7 = Alarm, 9 = Communicator Test

REPORTS	EVENT DATA	EVENT	NOTE:
	1 2 3 4 5 6 7 8	TYPE	
Burglary alarm for a zone	1 5 5 5 5 5 5 5	7	Zone 1 has a new alarm.
Fire alarm for a zone	1 5 5 5 5 5 5 5	7	Zone 1 has a new alarm.
Keypad fire	1 5 5 5 5 5 5 5	1	Event data 1 is the only one assigned.
Keypad fire restoral	3 5 5 5 5 5 5 5	1	This may look the same as Duress on some receivers.
Keypad help	1 5 5 5 5 5 5 5	1	Event data 1 is the only one assigned.
Keypad panic	1 5 5 5 5 5 5 5	1	Event data 1 is the only one assigned.
Burglary restoral for a zone	3 5 5 5 5 5 5 5	7	Zone 1 has been restored.
Fire restoral for a zone	3 5 5 5 5 5 5 5	7	Zone 1 has been restored.
Burglary trouble for a zone	1 5 5 5 5 5 5 5	5	Zone 1 is reporting a trouble condition.
Fire trouble for a zone	1 5 5 5 5 5 5 5	5	Zone 1 is reporting a trouble condition.
Burglary trouble restoral for a zone	3 5 5 5 5 5 5 5	5	Zone 1 is reporting a restoral for a trouble condition.
Fire trouble restoral for a zone	3 5 5 5 5 5 5 5	5	Zone 1 is reporting a restoral for a trouble condition.
Open report	8 2 2 2 2 2 2 2	2	User #8 opened. User # reported at event location 1, all others equal 2.
Close report	8 4 4 4 4 4 4 4	4	User #8 opened. User # reported at event location 1, all others equal 4.
Duress report	1 5 5 5 5 5 5 5	1	Event data 1 is the only one assigned. This report is initiated by opening using a Duress User PIN.
First open after alarm (cancel) report	8 2 2 2 2 2 2 2	2	Same as Open report.
Low battery	5 1 5 5 5 5 5 5	6	Systems Battery Low, Channel 2 of the System Reports.
Low battery restoral	5 3 5 5 5 5 5 5	6	Systems Battery Low, Channel 2 of the System Reports.
AC failure	1 5 5 5 5 5 5 5	6	AC Fail, Channel 1 of the System Reports.
AC failure restoral	3 5 5 5 5 5 5 5	6	AC Fail, Channel 1 of the System Reports.
Automatic test report	5 5 5 5 5 5 5 5	9	Communicator Test with zone alarm information.
Communicator test report	5 5 5 5 5 5 5 5	9	Communicator Test with zone alarm information.

REPORTS	EVENT DATA	EVENT TYPE	NOTE:
	1 2 3 4 5 6 7 8		
Remote programming successful report	5 5 5 5 5 3 5	6	NOT OFFICIALLY assigned, Channel 7 of the System Reports.
Remote programming failure report	5 5 5 5 5 1 5	6	NOT OFFICIALLY assigned, Channel 7 of the System Reports.
Local programming successful report	5 5 5 5 5 3 5	6	NOT OFFICIALLY assigned, Channel 7 of the System Reports.
Local programming failure report	5 5 5 5 5 1 5	6	NOT OFFICIALLY assigned, Channel 7 of the System Reports.
Keypad supervision failure report	5 5 1 5 5 5 5	6	System failure, Channel 3 of the System Reports.
Keypad supervision restoral	5 5 3 5 5 5 5	6	System failure, Channel 3 of the System Reports.
Fuse fault report	5 5 1 5 5 5 5	6	System failure, Channel 3 of the System Reports.
Fuse restoral	5 5 3 5 5 5 5	6	System failure, Channel 3 of the System Reports.
Exit error report	N/A	N/A	Format does not support this report.
Recent closing report	N/A	N/A	Format does not support this report.
System test start report	5 5 5 5 5 5 1	6	Walk Test, Channel 8 of the System Reports.
System test end report	5 5 5 5 5 5 3	6	Walk Test, Channel 8 of the System Reports.
Unspecified system trouble	5 5 1 5 5 5 5	6	System failure, Channel 3 of the System Reports.
Unspecified system trouble restoral	5 5 3 5 5 5 5	6	System failure, Channel 3 of the System Reports.
Bypass for a burglary zone	1 5 5 5 5 5 5	3	Zone 1 has been bypassed.
Bypass for a fire zone	1 5 5 5 5 5 5	3	Zone 1 has been bypassed.
Bypass restore for a burglary zone	3 5 5 5 5 5 5	3	Zone 1 is no longer bypassed.
Bypass restore for a fire zone	3 5 5 5 5 5 5	3	Zone 1 is no longer bypassed.
A communicator trouble occurred	5 5 5 5 1 5 5	6	Communicator trouble, Channel 5 of the System Reports.
A communicator trouble has restored	5 5 5 5 3 5 5	6	Communicator trouble, Channel 5 of the System Reports.

Contact ID Format

REPORTS	CID EVENT CODE	CID DATA FIELD
Burglary alarm for a zone	130	Zone Number
Fire alarm for a zone	110	Zone Number
Keypad fire	110	000
Keypad fire restoral	110 Restoral	000
Keypad emergency	122	None
Keypad panic	123	None
Burglary restoral for a zone	130 Restoral	Zone Number
Fire restoral for a zone	110 Restoral	Zone Number
Burglary trouble for a zone	370	Zone Number
Fire trouble for a zone	373	Zone Number
Burglary trouble restoral for a zone	370 Restoral	Zone Number
Fire trouble restoral for a zone	373 Restoral	Zone Number
Open report	401	User #
Close report	401	User #
Duress report	121	000
Partial close report	456	User #
First open after alarm (cancel) report	406	None
Low battery	302	None
Low battery restoral	302 Restoral	None
AC failure	301	None
AC failure restoral	301 Restoral	None
System normal test report	602	None
Communicator test report	601	None
Remote programming successful report	412	None
Remote programming failure report	413	None
Local programming successful report	306	None
Local programming failure report	306 Restoral	None

REPORTS	CID EVENT CODE	CID DATA FIELD
Keypad supervision failure report	330	Keypad Number*
Keypad supervision restoral	330 Restoral	None
Fuse fault report	300	None
Fuse restoral	300 Restoral	None
Exit error report	457	None
Recent closing report	459	None
System test start report	607	None
System test end report	607 Restoral	None
Unspecified system trouble	300	None
Unspecified system trouble restoral	300 Restoral	None
Bypass for a burglary zone	573	Zone Number
Bypass for a fire zone	571	Zone Number
Bypass restore for a burglary zone	573 Restoral	Zone Number
Bypass restore for a fire zone	571 Restoral	Zone Number
Communicator trouble	354	None
Communicator trouble restore	354 Restoral	None

SIA Format

SIA reporting allows the installer to select the type of event each report will send to the central station. For example, if a burglary zone is used as a 24 hour panic zone, it can now report as a PA (Panic Alarm) when using the SIA Format.

The event type is programmed in the extended digit of the report (addresses 24-36). To activate a report using the SIA Format, place a "1" (or any digit other than 0) in the first reporting digit. To select the type of event for this report, place one of the following values as the second (extended) digit.

Data Digit 2 value	SIA Report	Explanation
1	PA	Panic Alarm
2	PR	Panic Restore
3	QA	Emergency Alarm
4	QR	Emergency Restore
5	TA	Tamper Alarm
6	TR	Tamper Restore
7	UA	Untyped Zone Alarm
8	UR	Untyped Zone Restore
9	UT	Untyped Zone Trouble
*0	UJ	Untyped Trouble Restore
*1	YP	Power Supply Trouble
*2	YQ	Power Supply Restore
*3	YX	Service Required

Reports	SIA event code	SIA data field
Burglary alarm for a zone	B A	Zone Number
Fire alarm for a zone	F A	Zone Number
Keypad fire (A)	F A	000
Keypad fire restoral (A)	F R	000
Keypad emergency (1, 3, or B)	Q A	None
Keypad panic (*, #, or C)	P A	None
Burglary restoral for a zone	B R	Zone Number
Fire restoral for a zone	F R	Zone Number
Burglary trouble for a zone	B T	Zone Number
Fire trouble for a zone	F T	Zone Number
Burglary trouble restoral for a zone	B J	Zone Number
Fire trouble restoral for a zone	F J	Zone Number
Open report	O P	User #
Close report	C L	User #
Duress report	H A	000
Partial close report	C G	User #
First open after alarm (cancel) report	O R	None
Low battery	Y T	None
Low battery restoral	Y R	None
AC failure	A T	None
AC failure restoral	A R	None
Automatic Comm. test report	R P	None
Manual Comm. test report	R X	None
Remote programming successful report	R S	None
Remote programming failure report	R U	None
Local programming successful report	Y G	None
Local programming failure report	Y F	None
EEPROM checksum failure or keypad supervision failure report	E T	None
EEPROM checksum restoral or keypad supervision restoral	E R	None
Aux. power fault report	Y P	None
Aux. power restoral	Y Q	None
Exit error report	E E	None
Recent closing report	C R	None
System test start report	T S	None
System test end report	T E	None
Unspecified system trouble	U T	None
Unspecified system trouble restoral	U J	None

14.0 Program Address Quick Reference Guide

DESCRIPTION	ADDRESS	SECTION	PAGE #
AC Failure Report Delay	50	7.38	24
Account Codes	37	7.31	22
Alpha Label	12	7.12	15
Auto Bypass	10	7.10	14
Automatic Test Report Interval	48	7.36	24
Battery, AC Report	32	7.26	21
Default EEPROM	47	7.35	24
Dial Attempts	22	7.16	17
Duress Code	9	7.9	13
Easy Exit	10	7.10	14
Exit Error, Recent Closing, Comm. Fail	35	7.29	22
Fire Key	19	7.13	16
Force Arming	10	7.10	14
General Control	10	7.10	14
Guest Code	9	7.9	13
Help Key	19	7.13	16
Hours to First Auto Test Report	49	7.37	24
Keypad Assignment	11	7.11	15
Keypad Language	51	7.39	24
Keypad Report	24	7.18	18
Master Code	46	7.34	24
Open, Close, Duress Reports	31	7.25	20
Output Type	4	7.4	11
Outputs	8	7.8	12
Panic Key	19	7.13	16
Phone 1 Format	38	7.32	23
Phone 2 Format	39	7.32	23
Phone Number 1	40	7.33	23
Phone Number 1	41	7.33	23
Phone Number 2	42	7.33	23
Phone Number 2	43	7.33	23
Phone Number 3	44	7.33	23
Phone Number 3	45	7.33	23
Phone Number Control	21	7.15	17
Programmed Response Time	6	7.6	12
Programmer Code	46	7.34	24
Programming Report	33	7.27	21
Quick Arm	10	7.10	14
Report Control	20	7.14	16
Residential Mode	10	7.10	14
Restore With	7	7.7	12
Special Keys	19	7.13	16
Swinger Shunt	10	7.10	14
System Report	34	7.28	21
Test Reports, System Test	36	7.30	22
Time Delays	23	7.17	17
User Control	9	7.9	13
Zone 1 Alpha Label	13	7.12	15
Zone 2 Alpha Label	14	7.12	15
Zone 3 Alpha Label	15	7.12	15
Zone 4 Alpha Label	16	7.12	15
Zone 5 Alpha Label	17	7.12	15
Zone 6 Alpha Label	18	7.12	15
Zone Action	3	7.3	10
Zone Alarm Report	25	7.19	18
Zone Alarm Restoral Report	26	7.20	19
Zone Bypass	2	7.2	10
Zone Bypass Report	29	7.23	20
Zone Bypass Restoral Report	30	7.24	20
Zone Programming	1	7.1	9
Zone Response Time	5	7.5	11
Zone Trouble Report	27	7.21	19
Zone Trouble Restoral Report	28	7.22	19

Index

Symbols

3/1 18
3/1 with Parity 3, 18
3/1E 18
3/1E with Parity 3, 18
4/1 3, 18
4/2 18
50 Hz/60 Hz 3, 14

A

AC Failure Report 21
AC Failure Report Delay 24
AC Failure Restoral Report 21
Alpha Label 15
Answering Machine Bypass 17
Arming
 Force Arming 14
 Manual Arming and End of Exit Delay 13
 Quick Arming 14
Auto Bypass 14
Auxiliary Power Voltage Range 3
Auxiliary Regulated Power 3

C

Callback for Downloading 17
CANADIAN DEPARTMENT OF COMMUNICATIONS 31
Central Station Burglary Alarm 28
Closing Ringback 14
Communicator 3
Contact ID Format 3
Control Panel Current Draw 3

D

Default EEPROM 24
Dial Attempts 17
Dial Pulse 17
Dial Tone 17
Dialer Delay 17
Duress 13, 20
Duress Code 13

E

Easy Exit 14
Enclosure Housing 3
ENCLOSURE INSTALLATION 4
Exit Error 22

F

FCC
 COMPLIANCE NOTICE 30
 PHONE CONNECTION NOTICE TO USERS 30
First Open After Alarm 20
Fixed Report Formats 18
Follow Burg and Fire Alarm 13
Follow Fire Alarm 13
Force Arming 14

G

General Control 14
Grade A Household Burglary Alarm 26
Grade B Installations using Digital Alarm Communic 29
Grade C Installations using Digital Alarm Communic 29
Guest Code 13

H

HEX character 8
High Speed 4/9 Format 34
Hours to First Auto Test Report 24

Household Fire Alarm 26

I

Individual users 3
Input Power 3
Input zones 3
Install the Control/Communicator 4
Install the Enclosure 4
INSTALLATION GUIDE FOR U.L. LISTED SYSTEMS 25

K

Keypad Assignment 15
Keypad Fire Report 18
Keypad Fire Restoral Report 18
Keypad Help Alarm Report 18
Keypad Language Programming 24
Keypad Panic Report 18
Keypads 3
 Audible During Exit Delay 13
 DS7443 3
 DS7445 3
 DS7447 3
Keyswitch Arming Warning 13

L

Lightning Protection 3
Line Seizure Notice 3
Local Burglary Alarm 27
Local Program Successful 21
Low Battery Report 21
Low Battery Restoral Report 21

M

Master Code 24

N

NEW ZEALAND INSTALLATIONS 31

O

Operating temperature 3
Output
 Type
 Armed 12
 Follow Burg Alarm 13
 Follow Keypad Sounder 13
 Ground Start 13
 Invisible 11
 On During Entry Pre-Alert 12
 On for 8 seconds after [System Reset] is entered 12
 Pulsing 11
 Silent 11
 Steady 11
 System Status (Ready to Arm) 13

P

Partial Close 20
Personal Dialing 3
Personal Dialing Format 32
Phone #1 (Reporting) 23
Phone #1 Format 23
Phone #2 (Reporting) 23
Phone #2 Format 23
Phone #3 (Remote Programming) 23
Phone Number Control 17
Police Station Connection 27
Programmable Output 1 3
Programmable Output 2 3
Programmable Output 3 3
Programmed Response Time 12
Programmer & Master Codes 24

Programming
HOW TO PROGRAM THE DS7060 8
PROGRAMMING THE DS7060 8
Pulsed Formats 18

R

Recent Closing 22
Remote Program Successful 21
Remote Program Unsuccessful 21
Report Control 16
REPORT PROGRAMMING 32
REPORTS 18
Reports
Account Codes 22
Automatic Test Report 22
Battery, AC Report 21
Comm. Failure Report 22
Comm. Restore Report 22
Communicator Test Report 22
Exit Error, Recent Closing, Comm Failure Report 22
Keypad Report 18
Open/Close Duress Report 20
Programming Report 21
System Report 21
Zone Alarm Report 18
Zone Alarm Restoral Report 19
Zone Bypass Report 20
Zone Bypass Restoral Report 20
Zone Trouble Report 19
Zone Trouble Restoral Report 19
Restore when Disarmed (or Reset) 12
Restore when Sounders Silence 12
Restore with Zone 12
Ring Count 17

S

SIA Format 37
Special Formats 18
Special Keys 16
Disabled 16
Fire Key [A] 16
Help Key [B] 16
Invisible 16
Panic Key [C] 16
Pulsing Audible 16
Steady Audible 16
SPECIFICATIONS 3
Storage temperature 3
Swinger Shunt 14
SYSTEM OVERVIEW 3

System Test 22
System Test Restoral 22
System Trouble 21
System Trouble Restoral 21
System Worksheets 6

T

Test Reports, System Test 22
Time Delays 17
Tone with Auto Switch to Pulse 17
Trouble 13

U

U.L. Listings
DS7060 U.L. Listings 25
Installation Considerations 25
Programming the DS7060 26
User Control 13
Users 3

W

WIRING 5
Wiring and Programming Information for Installatio 30

Z

Zone 3
Response Time 3
Type
24-Hour Auxiliary 9
Disabled 9
Fire Zone 10
Fire Zone with Verification 10
Interior Follower 9
Interior Home/Away 9
Interior Instant 9
Keyswitch On/Off 10
Keyswitch Toggle 10
Perimeter Delayed 9
Perimeter Follower Homeguard 9
Perimeter Homeguard 9
Perimeter Instant 9
Silence Audible 9
Zone Action 10
Zone Alarm Restoral 19
Zone Bypass 10
Zone Programming 9
Zone Response Time 11
Zone Restoral Options 12
Zone Trouble 19
Zone Trouble Restoral 19

